

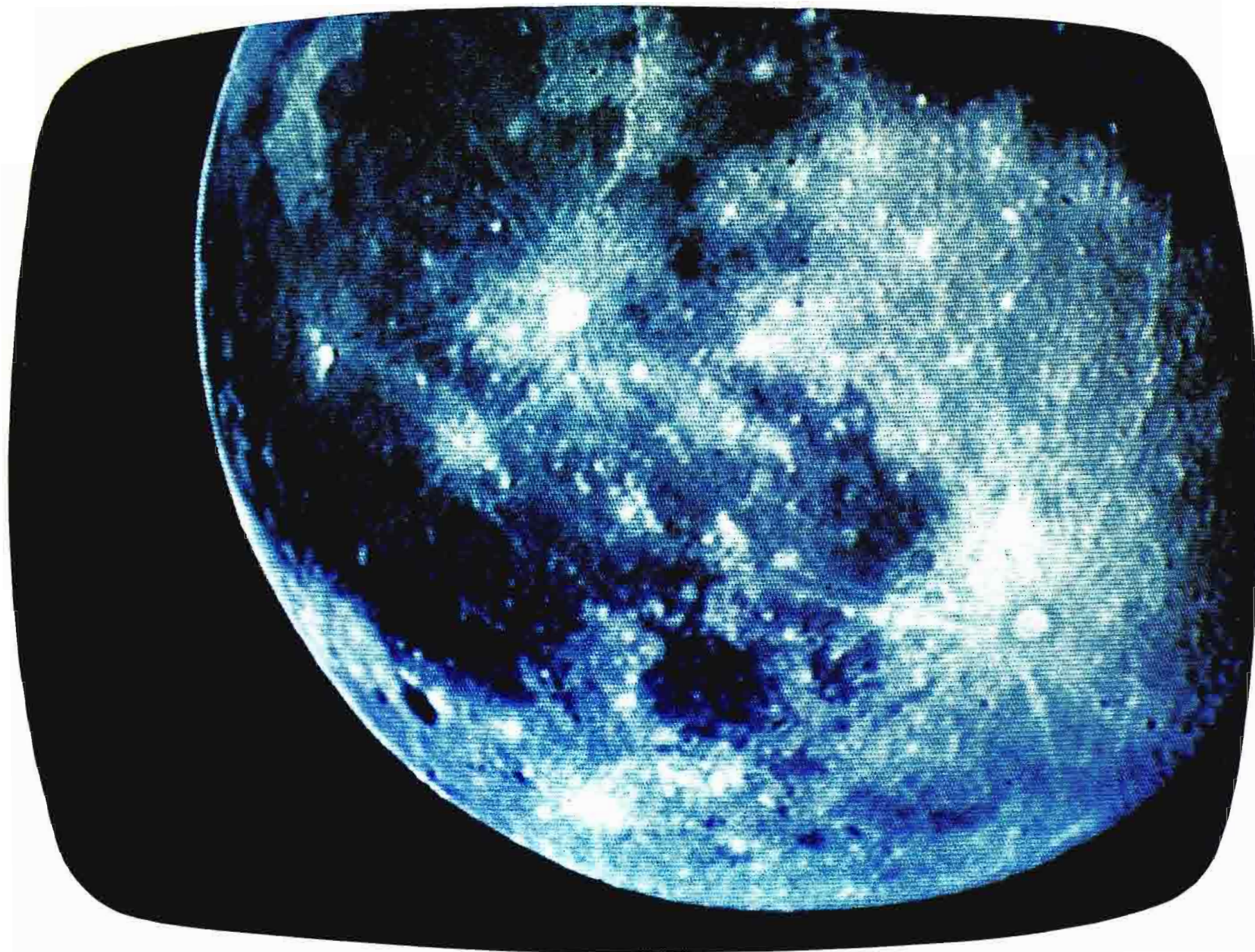

TV Studio in a Garden Court at WSJS-TV



Unretouched photograph taken directly from monitor.

Moon-Shot Proves TK-42 Performance

High resolution in a color camera gives pictures extra detail to produce finest programs and commercials. What does it take to provide this resolution capability? It takes a big 4½-inch image orthicon tube, for big picture sharpness. Add dynamic contrast range, to handle broad variations between highlight and shadow. And sensitivity, to cover wide ranges in lighting. In short it takes all three to produce the finest color pictures. We know TK-42/43 cameras have all these capabilities—but how could we prove it?

We set up a camera with telescopic lens to shoot the moon. The proof is in the unretouched monitor photo above: Prominent features of lunar terrain are sharply distinguishable. The TK-42/43 provides resolution to capture crater detail; sensitivity to compensate for extreme light loss with a telescopic lens; dynamic contrast to faithfully reproduce the tremendous range of highlight-to-shadow areas.

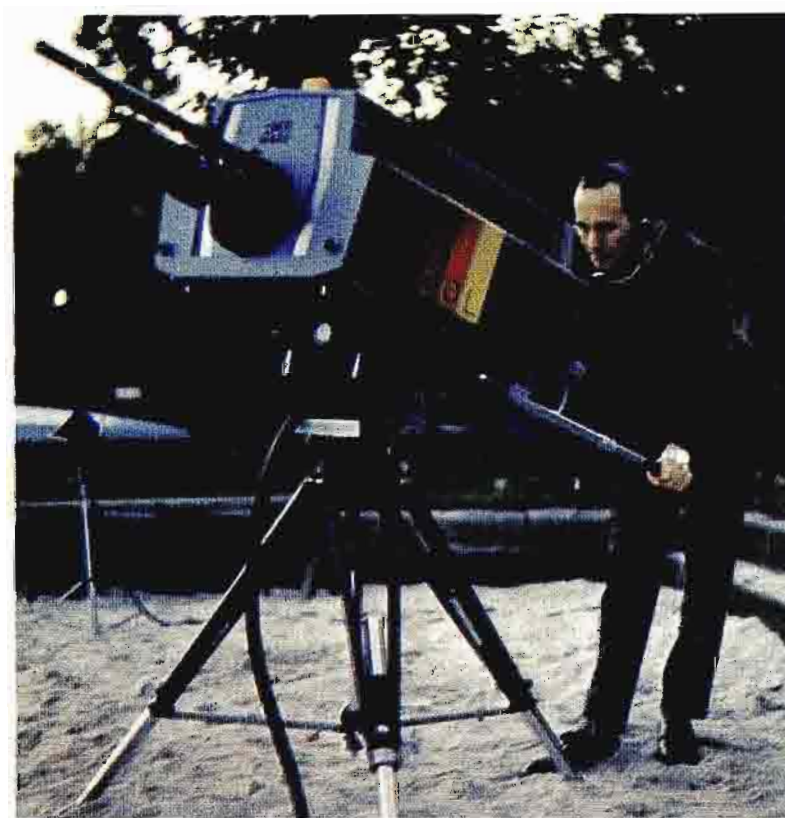

This camera has got what it takes to turn on viewers. And you don't have to shoot the moon to prove it! Ask your RCA Field Man.

RCA Broadcast
Equipment

RCA Broadcast News

Published by BROADCAST SYSTEMS DEPARTMENT
RCA COMMERCIAL ELECTRONIC SYSTEMS DIVISION

CONTENTS

| | |
|--|----|
| New Look for Local Radio/TV, WSJS | 6 |
| Kentucky Educational Television | 14 |
| Serving the Troops Overseas, DINFOS | 18 |
| Editing TV Tapes | 24 |
| Television Comes to Tierra Del Fuego | 30 |
| New TR-60 TV Tape Recorder | 36 |
| New TA-19 Video Processing Amplifier | 41 |
| RCA West Coast Information Center | 46 |

PRICE . . . single copies, \$2.50 each

Copyright 1968 Radio Corporation of America, All Rights Reserved

100-STORY JOHN HANCOCK CENTER SLATED AS ANTENNA SITE FOR FIVE CHICAGO STATIONS

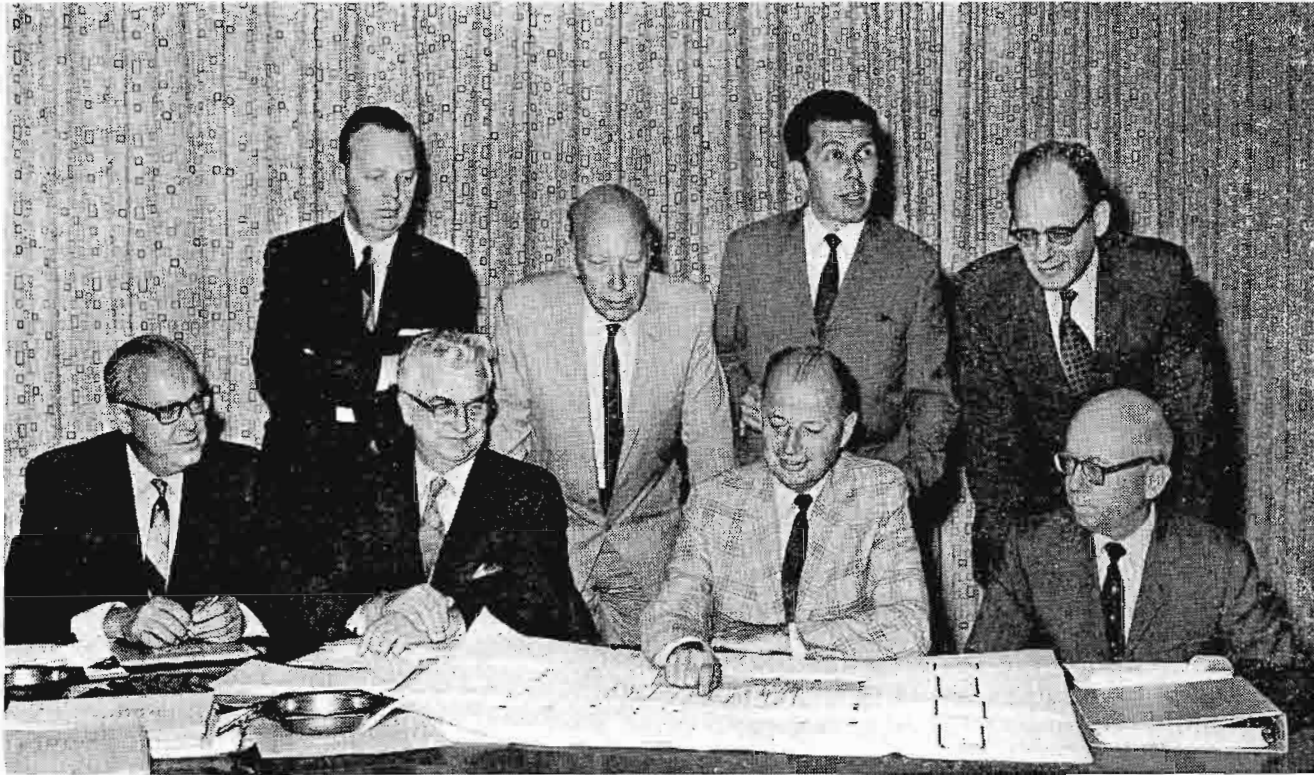

Chicago broadcasters antenna committee is shown after two-year study that culminated in \$1,300,000 in agreements with RCA for Hancock project. Seated from left, are Ralph F. Batt, Vice President and Engineering Manager, WGN-TV; Woodrow Crane, Chief Engineer, WGN-TV; William Kusack, Committee Chairman and Vice President-Chief Engineer, WFLD-TV; Luther A. Pierce, Director of Technical Operations, WBBM-TV; (standing), Curt Pierce, Manager, Technical Operations, WMAQ-TV; Walter Lanterman, Transmitter Supervisor, WMAQ-TV; Yale Roe, Manager, WSNS-TV, and R. L. Rocamore, Manager, Antenna Engineering, RCA.

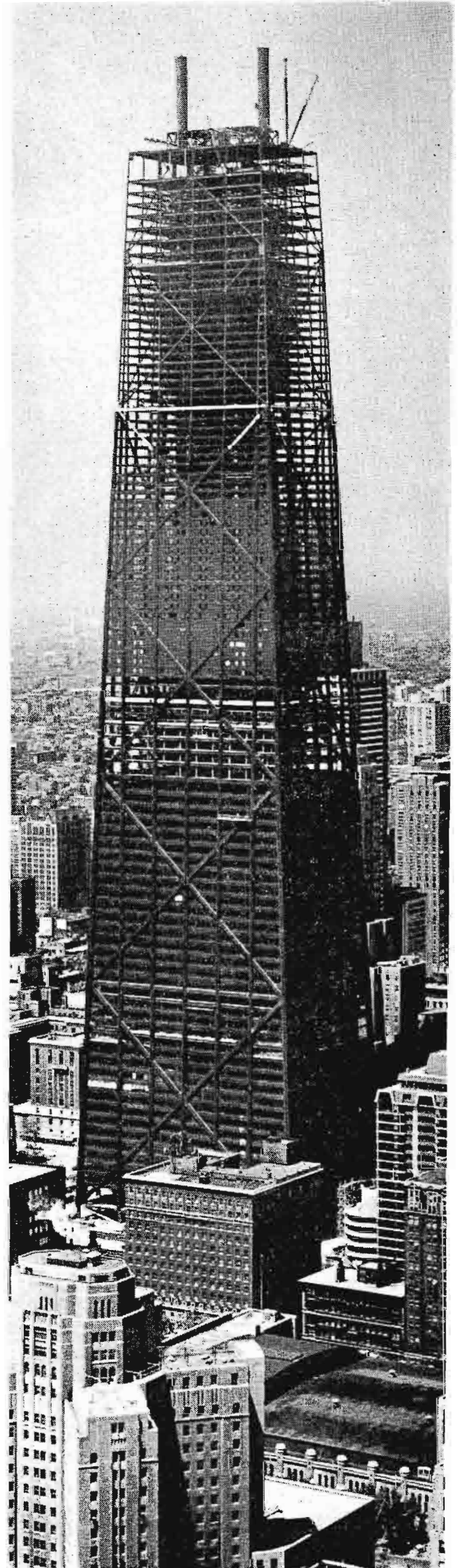
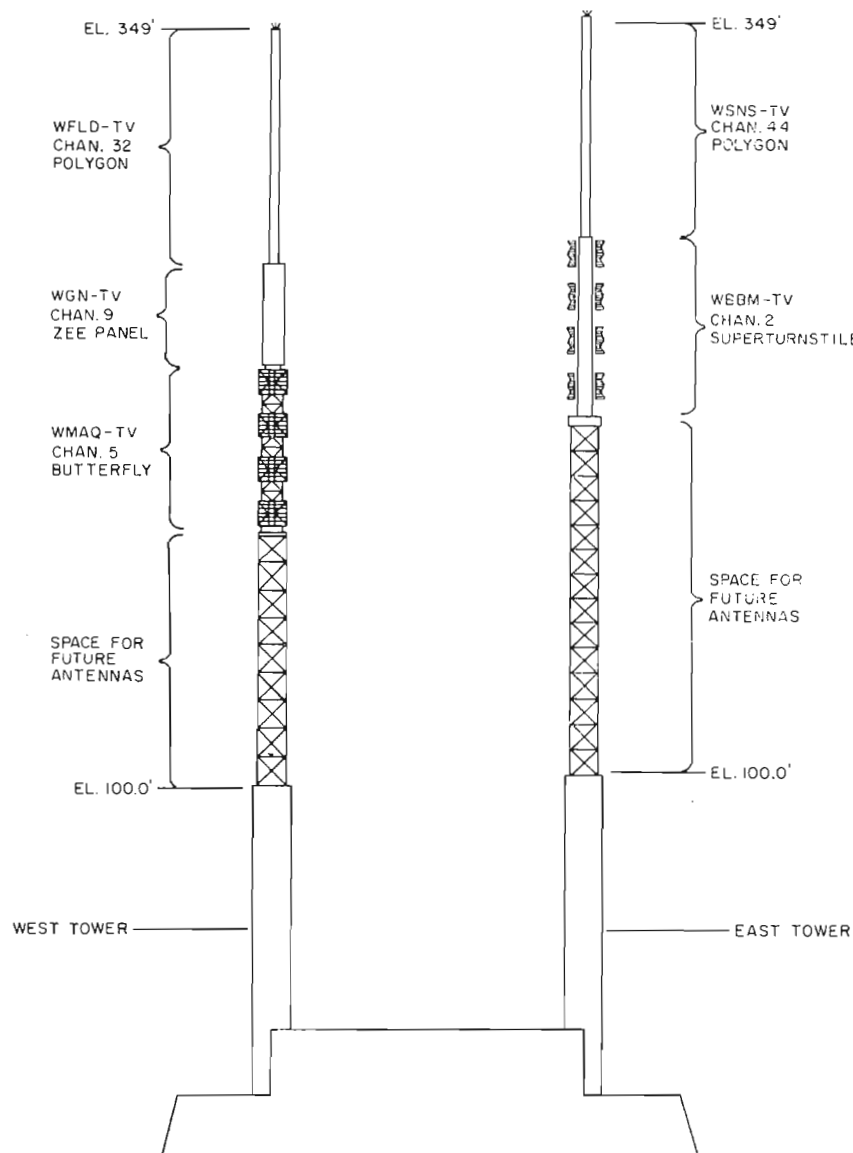

TV antennas will be mounted on twin tubes rising from 'Big John's' roof. Drawing at left shows configuration of antennas.

OPENING OF KENTUCKY NETWORK, LARGEST STATE WEB, MARKS MAJOR ADVANCE IN EDUCATIONAL TV



Gov. Louie B. Nunn (right) officially opens Kentucky's 12-station ETV network, the nation's largest state system, which uses \$4.2 million in UHF transmitting equipment supplied by RCA. With him (from left) are Dr. Robert R. Martin, Eastern Kentucky Univ. President and ETV Authority member; Manthis Manchikes, Univ. of Ky., Authority member; Aluis Temple, Mgr., Radio Station WKCT, Bowling Green, Authority member; O. Leonard Press, Executive Director, ETV Authority, and Roy H. Owsley, Chairman, ETV Authority. The start-up ceremony occurred September 23 in the network's Lexington studios before regular morning programs began. The network will transmit programs in both color and black-and-white, with color shows being originated from film and TV tape until "live" color studio equipment is fully installed and operative later this year. The 12 transmitting sites were chosen to assure coverage of schools and virtually all households represented by the state's three million population. The equipment package supplied by RCA also included two translators to provide fill-in coverage in areas remote from the stations.

RCA WILL DESIGN, EQUIP AUSTRIAN COLOR CENTER

RCA has received a major management contract from Oesterreichischer Rundfunk GmbH. (ORF), the Austrian broadcasting authority, to design a complete new color TV production center in Vienna and provide it with approximately \$2 million in studio equipment. The agreement calls for RCA to translate the requirements of the Austrian broadcaster into a full-scale and operating color TV technical facility.

First members of an RCA management team, which will have full project supervision over such matters as systems design and installation of video, audio and communications facilities, already are on the scene in Vienna. This part of the agreement with ORF will be carried out through RCA's wholly-owned subsidiary company, RCA International Ltd.

RCA studio equipment to be supplied will include a quantity of TK-44A color studio cameras and TK-27 color film systems. The TK-44A is a new lightweight three-tube color camera which RCA introduced at the 1968 NAB convention. More than 600 TK-27 systems currently are in use.

The new Vienna facility, which will be known as ORF's Television Center Kuniglberg, will become one of Europe's largest and most modern television production facilities.



PK-501, NEWEST MEMBER OF 'PROFESSIONAL TV' CAMERA LINE, WEIGHS BUT 8 POUNDS

Newest, lightest and lowest priced member of RCA's "Professional Television" monochrome TV camera line, the PK-501, made its debut recently. The vidicon camera weighs but 8 pounds, is encased in a four-inch diameter cylinder, 13 inches long, and is priced at \$1,195.

Primary market for the PK-501 is expected to be surveillance applications, although educational and training TV systems, among others requiring budget-priced equipment capable of producing

good quality pictures, are expected to use it.

The new camera features automatic light compensation over a brightness range of 4,000 to 1, with only an insignificant change in picture output level. Horizontal resolution from the one-inch vidicon is 600 lines in the picture center.

Many of the PK-501's functions are automated, leaving only a minimum of controls to be adjusted for reliable and unattended operation over long periods.

\$1,400,000 PACKAGE IS READIED FOR SAO PAULO

RCA is supplying approximately \$1,400,000 in studio and transmitting equipment for a new combination TV-FM broadcast station in Sao Paulo, Brazil. The order from the Fundacao Padre Anchieta (Father Anchieta Foundation) is one of the largest ever received by RCA to equip a foreign broadcast facility.

The two stations, along with existing AM facilities, will be operated by the Radio and TV Educational Center for Sao Paulo. Programming will concentrate on cultural and educational activities and plans call for many remote pickups at theaters, opera houses and similar locations.

Major TV items supplied by RCA include three TR-70 high-band TV tape recording systems, two film "islands," two program production switchers and master control systems and a 25-kilowatt VHF television transmitter. RCA also will supply a TR-50 TV tape recorder for use in the station's mobile TV unit along with a TS-40 switching system, audio equipment and a microwave to link the vehicle with its home base.



During RCA-Camden visit, Dr. Carlos A. Schmidt Sarmiento, Brazilian broadcaster, and his wife are televised by TK-42 color camera in demonstration studio.

In addition to a 10-kilowatt FM transmitter and circularly-polarized FM antenna, the RCA agreement includes a solid-state microwave system for relaying radio and TV programs simultaneously from the studios to the transmitters, a distance of about 10 miles.

FIRST 'BUTTERFLY' TV BROADCAST ANTENNA NETTED BY WDBO-TV FOR 1,482-FOOT TOWER

WDBO-TV, Orlando, Florida, will become the nation's first television station to install the new RCA "Butterfly" broadcast antenna. The six-bay panel antenna was included in an order for a complete new transmitting facility placed for the Channel 6 station by its owners, The Outlet Company.

Billy L. Patton, Director of Engineering for Outlet, said the order also included a TT-25DL transmitter and a TVM-6 dual microwave system for linking WDBO-TV studios to the new transmitting site, a distance of approximately 19 miles.

The Butterfly will be mounted on a new 1484-foot tower and is expected to increase the station's grade B viewer

coverage by 24 percent when broadcasts begin from the new site late this year. While the antenna will radiate the directional signal pattern presently required by the station, it can readily be field modified for omni-directional service should WDBO-TV's requirements change in the future.

Another advantage is its ability to permit operation of a tower elevator inside the antenna to facilitate inspection and servicing of the antenna and the changing of tower lights. Introduced at the 1968 NAB convention, the Butterfly gets its name from wing-like radiating elements that are positioned backwards toward the reflectors for optimum impedance and radiation characteristics.



So fair the safari, as Candy Smith sets out with the Super-Carfone 500, newest addition to RCA's line of mobile radios.

WPIX TRANSMITTER 'SHACK' A THING OF FUNCTIONAL BEAUTY

Decor can be ultra-utilitarian, as well as beautiful, as WPIX, Inc. is proving these days at its TV and FM-Stereo transmitter facilities in New York's Empire State Building.

In addition to good looks—as these pictures of the RCA equipment there attest—WPIX's engineering V.P. Otis Freeman is proudest of the fact that the TV and FM-Stereo stations use new equipment for both on-air and standby operations. "Actually," says Mr. Freeman, "it's more than pride that motivated us to set up the transmitting facilities literally as engineering paradises. We're better off with all-new equipment. If we were using older equipment for standby—the most common practice in broadcasting—we'd have huge maintenance problems. Now it's a rarity when our transmitter log shows where a headache develops."

Then he adds with a slight smile: "Matter of fact, if the Excedrin people are looking for locales to shoot for their TV commercials, they automatically bypass our site. Too tranquil. Too peaceful. Too good-looking. And too conducive to smiles and happy faces."

All wiring, cooling and high tension facilities—the polished brass, trussed steel clutter normally associated with tv-radio transmitter facilities—are hidden in the polished decor panels of the twin RCA TV transmitters.

For simplicity in handling, and greater efficiency, WPIX engineers also designed upright control panels centrally located so that an on-duty engineer sitting at the single desk, controls both transmitters and can switch from one to the other in split-seconds.

If both transmitters are "fired up," notes Dominick Bruno, assistant engi-

neer, "it's a split-second switch. If we have to switch from one to the other from a cold start it takes just 20 seconds longer." The station similarly uses upright control paneling for its FM-Stereo twin-units.

WPIX built the new facilities coincident with installation of its new antenna on the all-station mast on the Empire State Building. Installation of the transmitters in the "shack" on the 81st floor was begun in 1966 and completed early this year for both the TV and FM facilities.

The suite boasts one other item, too—pile carpeting on the floor between the facings on the equipment. "Just as economical as inlaid linoleum tiles," notes Freeman, "and a lot more home-like and comfortable for the men working there." Truly, it's an engineering castle in the sky.

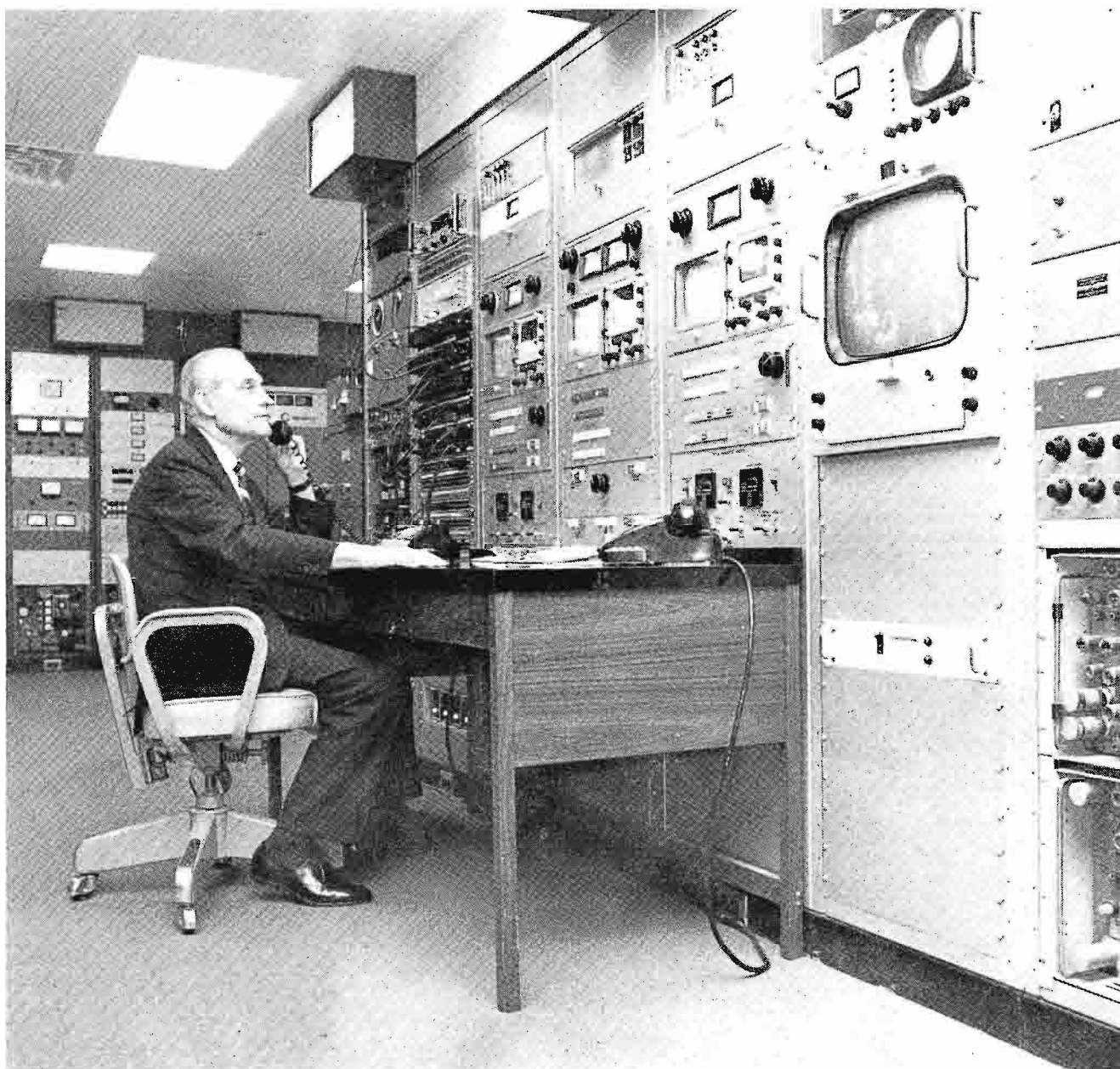

Dominick Bruno, WPIX Assistant Chief Engineer, is master of all he surveys at his control point in the Empire State Building transmitter room high above New York.

'THEY'RE OFF!' AND THE TK-42S GET THE ACTION

Color television made its debut at the Atlantic City Race Course this year when an RCA closed-circuit color system was used to record and play back races for judges and fans, and as a program source for area television stations.

During the 60-day racing season, TK-42 color cameras provided "live" programming every Saturday afternoon of the track's featured stakes race over WCAU-TV, Philadelphia.

Atlantic City is the second track to use color television to record and play back races for judges and fans. The color video tape patrol, first tried at Monmouth Park, N. J., during the 1968 racing season there, was designed by RCA and Video Projects, Inc.

Color TV "instant replay" permits stewards and track officials to monitor races and other events, while at the same time keeping on-the-scene racing fans posted on betting odds, race results, photo finishes and other track information. It also gives the track built-in capability for making color tapes of feature races and other events for re-broadcast over commercial TV stations.

NEW LOOK FOR LOCAL RADIO/TV WSJS, WINSTON SALEM

HAROLD ESSEX, President
Triangle Broadcasting Corporation

Broadcast House, the home of the WSJS stations in Winston-Salem, was conceived, designed and constructed to be not only a highly functional broadcast facility, but a community showplace as well. We think we succeeded fairly well in attaining that dual goal.

A broadcasting operation, in a sense, belongs to the community in which it is located. With this in mind, we wanted to construct a building of which the community could be proud. We're located on the edge of a residential (apartment) area and a "factory style" building wouldn't have made us many friends. As it turned out our neighbors "point with pride" at what we've done.

Another plus, we feel, is the big gain in employee morale that has resulted. The staff is proud of the plant and delighted with the attractive and comfortable working quarters. That "plus" alone made our careful planning worthwhile.

Planning of Broadcast House took place over a period of at least five years. One complete set of architects' plans was discarded at one point and we started all over. We're glad we did, because although that was a few thousand dollars down the drain, it allowed us to make some major changes, along with many minor ones, that resulted in a much more acceptable and workable final product.

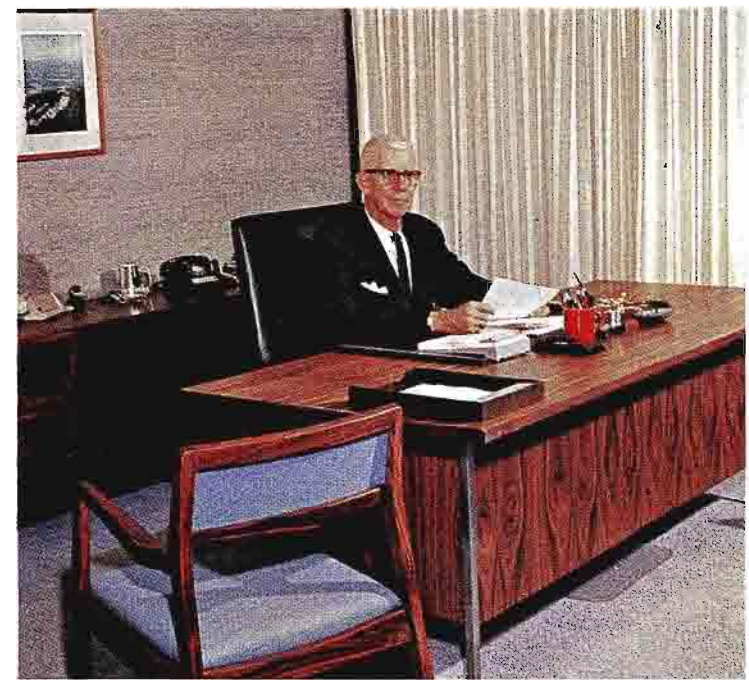

BROADCASTING PIONEER, Harold Essex joined WSJS in 1939, became General Manager in 1942, guided station's development into television.

RESIDENTIAL LOOK is a planned feature of the new WSJS building. An architectural accent is its eight-foot square, plexiglas enclosed microwave tower rising 86 feet above ground level. The tower is illuminated with a soft glow at night.

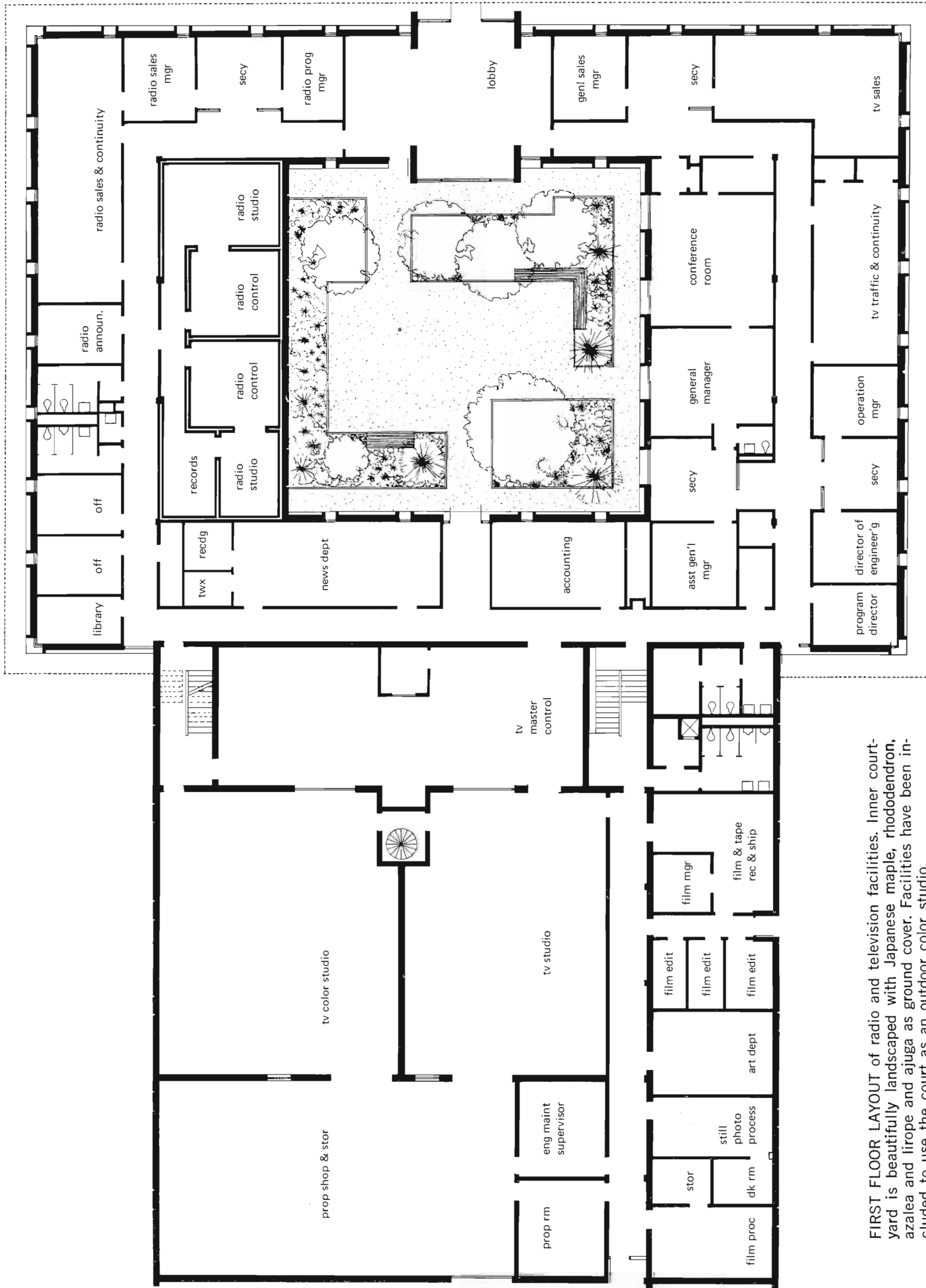

FIRST FLOOR LAYOUT of radio and television facilities. Inner courtyard is beautifully landscaped with Japanese maple, rhododendron, azalea and irope and ajuga as ground cover. Facilities have been included to use the court as an outdoor color studio.

TV MASTER CONTROL was specially tailored to WSJS programming requirements with the aid of RCA systems engineers. Here in this compact, centrally-located console arrangement are facilities for control of live and film camera, manual master control of all audio and video signals, and a station-break automation system.

The public space and offices are all grouped in a square around a central court. Television sales, programming, traffic and continuity and associated functions are on one side; radio sales, programming, traffic and continuity and studios are on the opposite side of the court. Public space, the lobby and receptionist are, naturally, on the front side of the court, while the news operation which serves both radio and television occupies the rear section of the court. The television operations, including color studios, color and black and white film processing, art department, prop department, production facilities and attendant services occupy the entire two-level rear section of the building.

The terrain of the three-acre plot on which the building is located allowed us to turn what would normally be basement space into ground level space on one side of the building. In this area is housed the promotion department, public affairs and special projects for television, a complete snack bar, a large

shop for the engineering department and the air conditioning equipment. The latter, by the way, is of necessity a major installation, with dual equipment to insure a minimum risk of outage.

Landscaping architects planned the exterior of the plant and the planting in the interior court. The tower that rises above the building, and which has caused no little comment, is also functional. It houses the main microwave units that transmit programs to the television transmitter, 18 airline miles away, and also various receiving antennae. Normally this is done with an ordinary steel tower, but in our case we wanted nothing of that nature that would detract from the general appearance of the plant. Hence, the decorative tower idea was conceived. At night a soft gold light shines through the plexiglass skin and makes an ideal landmark.

Oh, and by the way, we decided to go "RCA all the way" in equipping our new plant. That, too, we find was a wise decision.

FILM CAMERA CONTROL area handles TK-27 color film camera (left section) and two TK-22 monochrome cameras (right section).

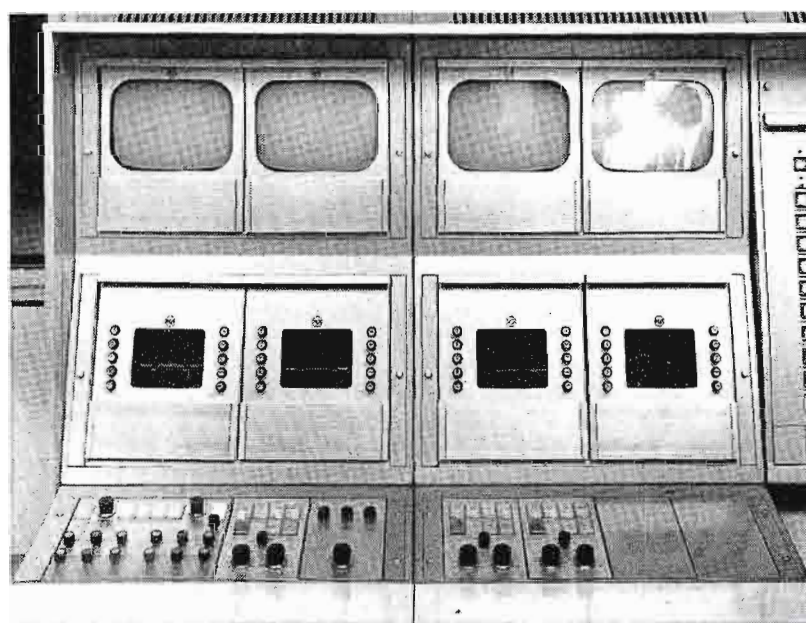

STATION BREAK AUTOMATION section houses TSA-3 panel capable of handling 15 video and 7 audio inputs in a preset sequence of ten events. Panel at the operator's right includes remote control of sync generators and stabilizing amplifiers.

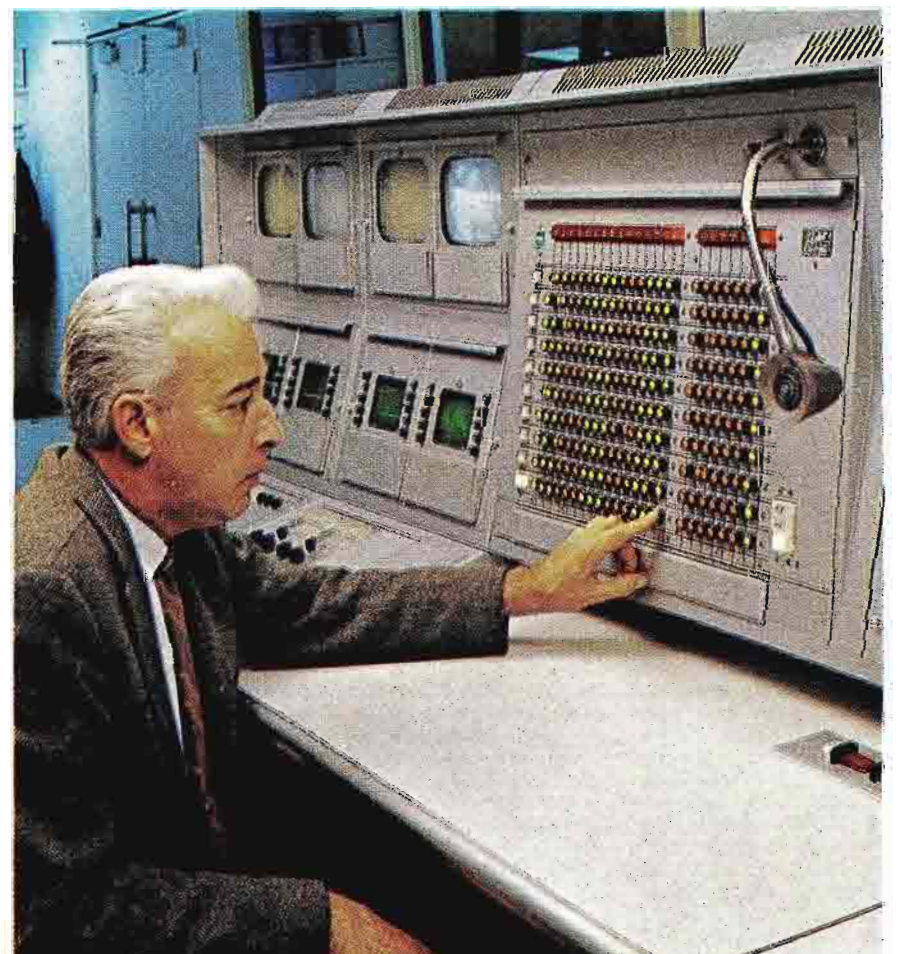

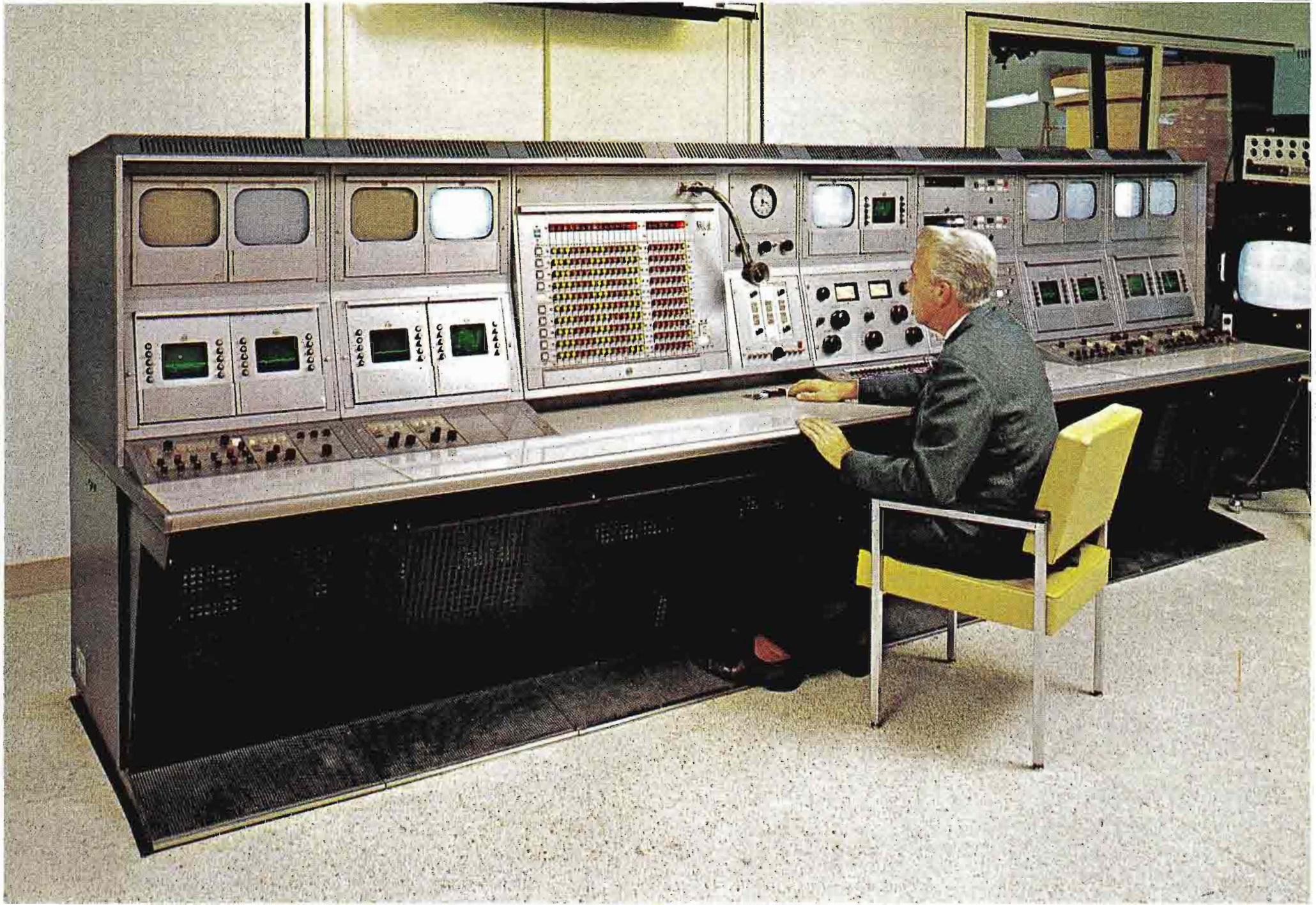

MANUAL OPERATION section includes (at left) a custom built audio master and TS-40 video switching panel complete with effects. At right are cartridge tape decks and machine control panel.

LIVE CAMERA CONTROL area is located at the right end of the console to give operator view into color studio equipped with two TK-42 color TV cameras.

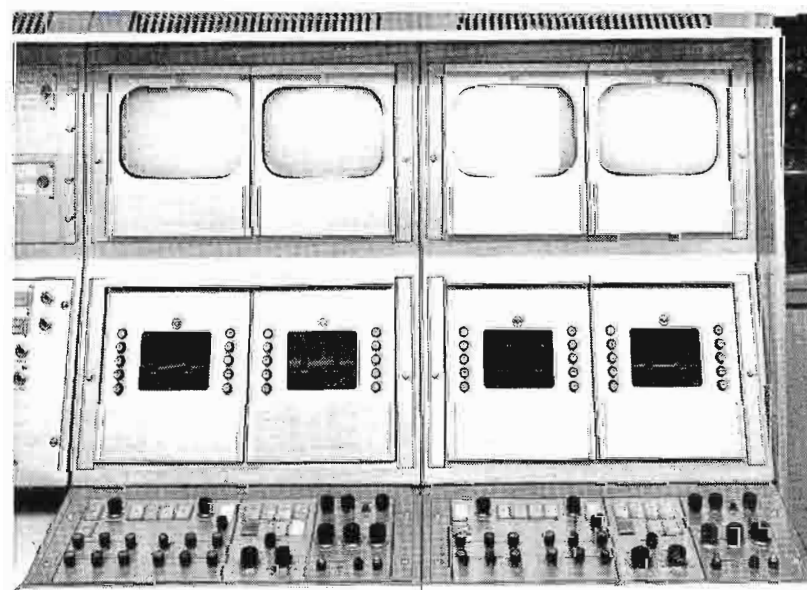
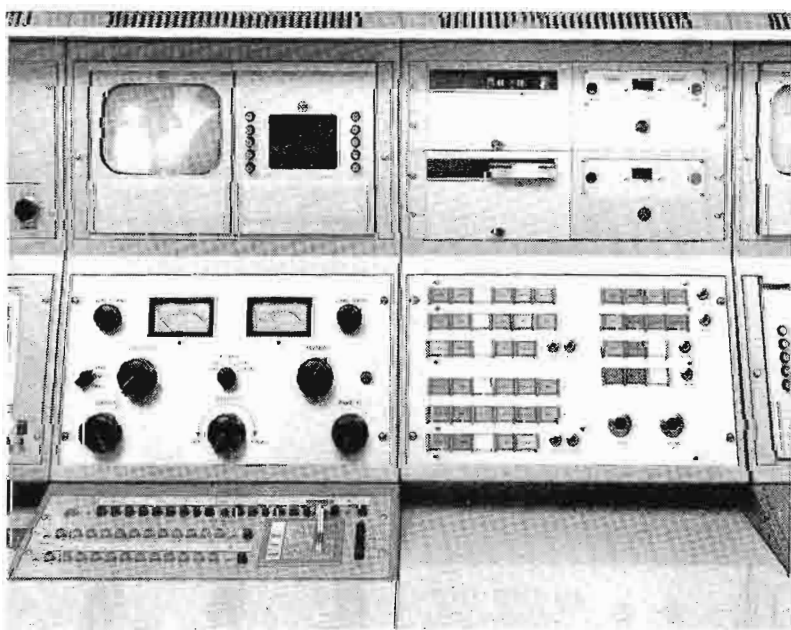

A "New Look" Broadcasting System

What we purchased from RCA was more than a group of tape, film, camera and switching equipments; it was a system. A system which reflected our program and production needs, both present and expected. A system that was planned with the same attention to functional detail and provision for future expansion as our building. The result, we believe, is indeed a community showplace—in both appearance and operation.

Technical Study

While initial architects' plans were being considered, engineering management was visiting new television

plants throughout the South and East studying the most modern ideas in physical facilities and broadcasting equipment. And thus the facilities plan took shape. Local needs were determined to be:

- (1) Color—Availability to national, regional and local advertisers of a complete range of color facilities . . . live, tape and film.
- (2) Technical Proficiency—As represented by transistorization, use of circuit stabilization techniques and other developments which contribute to reliable operation, minimum downtime and long useful life.
- (3) Operational Efficiency—Use of a central equipment area for maximum utilization and mini-

SPACIOUS COLOR STUDIO measures 40 by 50 feet, has access to drive-in autos, and permits use of standing sets. Elevated control room (see inset) provides vista of production area below.



mum redundancy; automation to take the panic out of station-break periods.

- (4) Protection for the Future—Use of latest design equipment for protection against obsolescence and most value from equipment investment.

System Highlights

The system as determined with the aid of RCA Systems Engineering is pictured on these pages. TV master control as shown on the floor plan serves as the central equipment area. Here is located all of the TV studios rack equipment—camera, switching, distribution, microwave, remote radio transmitter monitoring and others. Beyond this rack grouping and

centrally located in the area is the master control console with film and live camera controls, audio and video switching and automation equipment. Beyond this two additional equipment groupings—the film islands and the TV tape recorders.

The system includes mostly standard, but some custom-built equipment. It is the custom-built touches that make maximum utilization of the standard equipment while tailoring the system to our own program requirements. The central equipment area has provision for installing additional equipment should a second studio (33 by 50 feet) be activated for color or should additional color film islands or television tape machines be required.

COLOR CAMERA SEMINAR is hosted by WSJS-TV. Upon delivery of TK-42 cameras, RCA engineers conducted operations seminar for WSJS and other nearby station personnel.



CUSTOM-BUILT INTERCOM SYSTEM links all equipment positions and areas of machine control. Panel shown is located in the color studio control room, atop the machine control panel adjacent to the program switcher.

COLOR PROGRAM SWITCHER is a TS-40 type similar to that used in master control with the addition of special effects facilities. An identical switcher is also installed in the control room of a second studio.

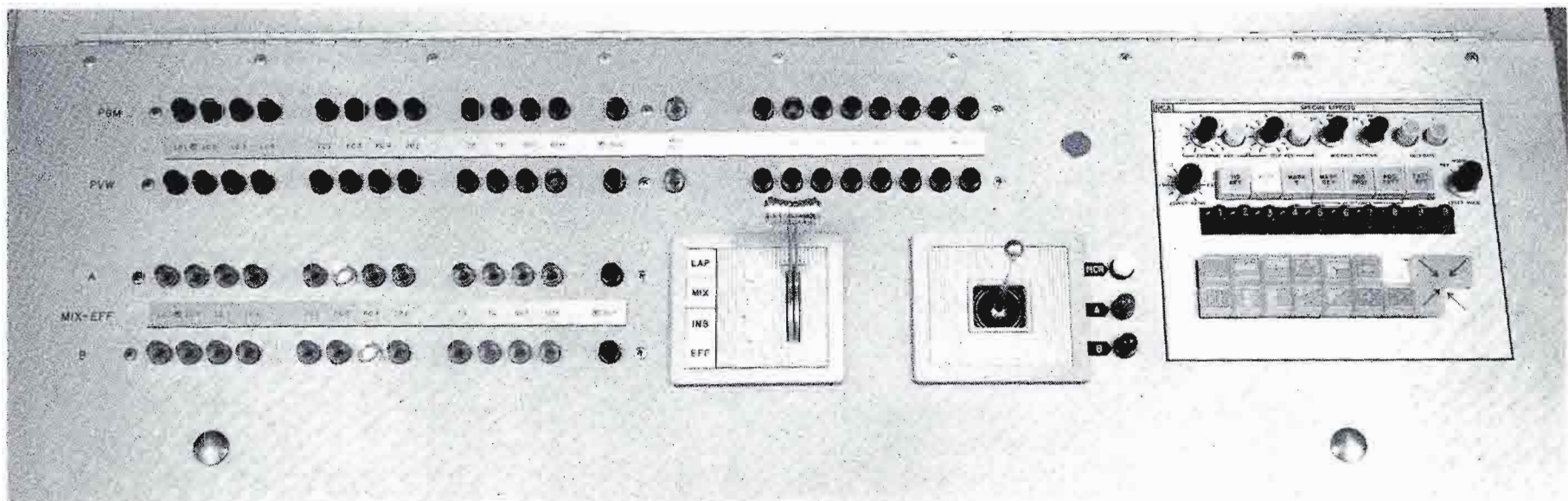
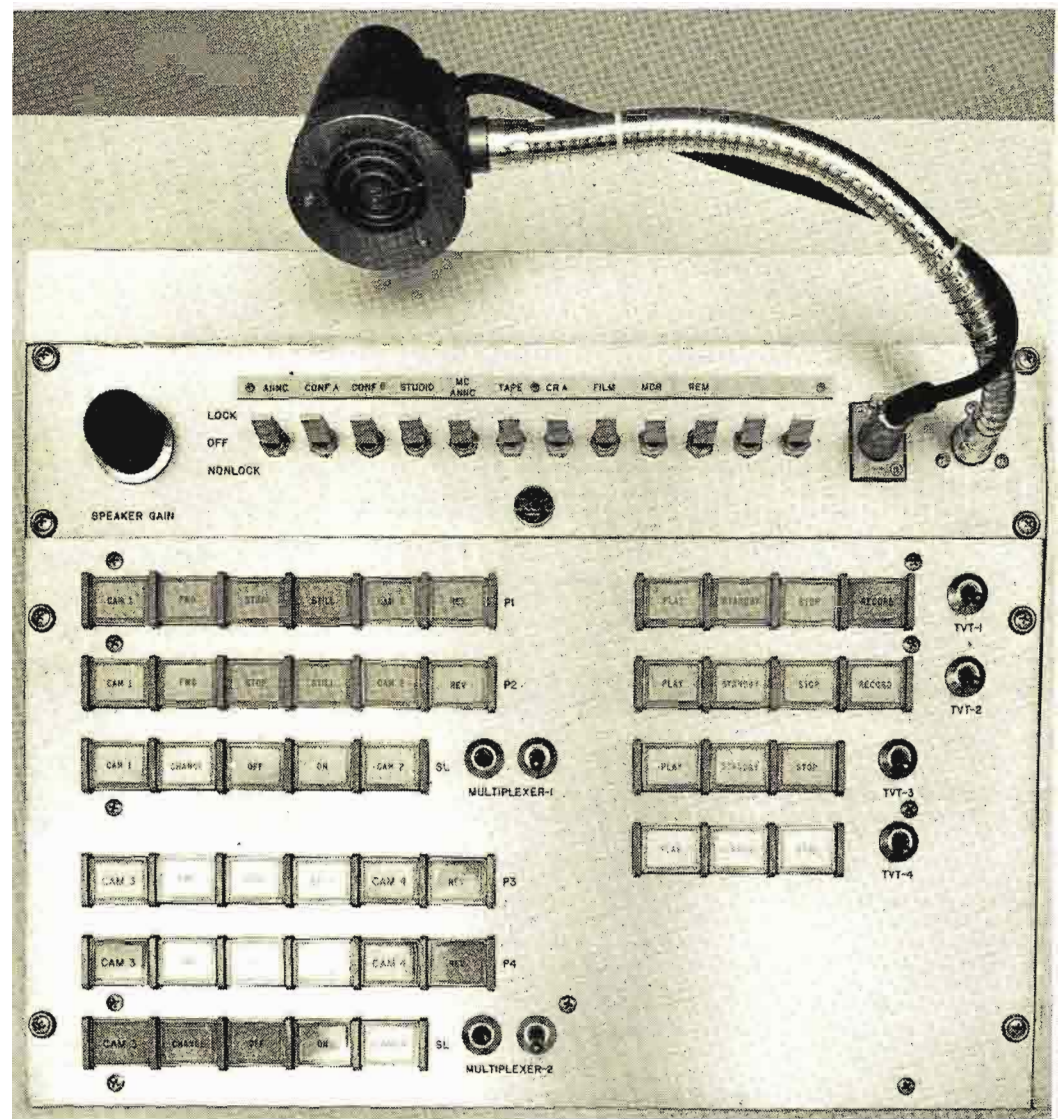



HIGH BAND COLOR TAPE production facility is provided by TR-70 recorder (right). WSJS was the first TV station to install this highband model. Also shown is TR-22 recorder, which has since been highband retrofitted, and custom intercom and input and test signal selection panels (center).

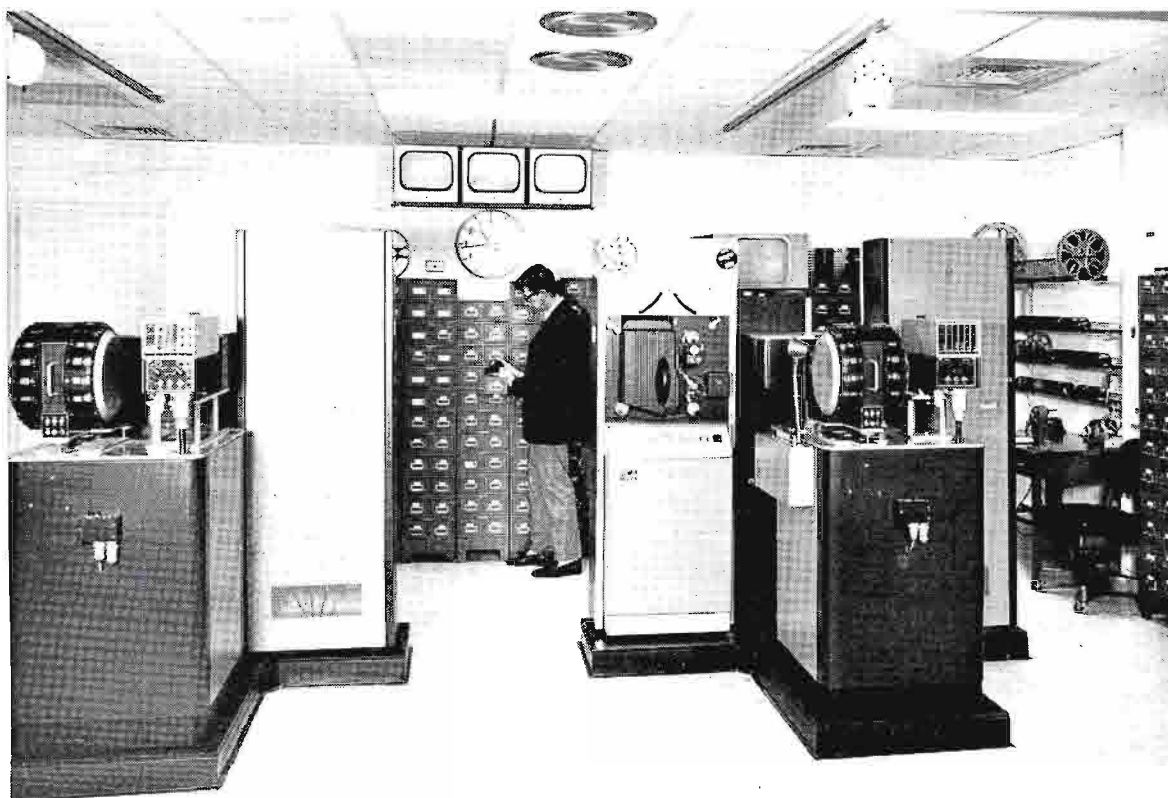

FILM AREA includes two film islands, storage and film editing facilities. Latest-design equipments for color and monochrome include a TK-27 4-vidicon color film chain and two TK-22 monochrome film chains.

TV TAPE COMMERCIALS and program segments are pre-loaded here on two TR-3 high-banded TV tape players which are activated by the automation system. In this manner tape commercials can be handled in the same manner as film clips in the projectors.



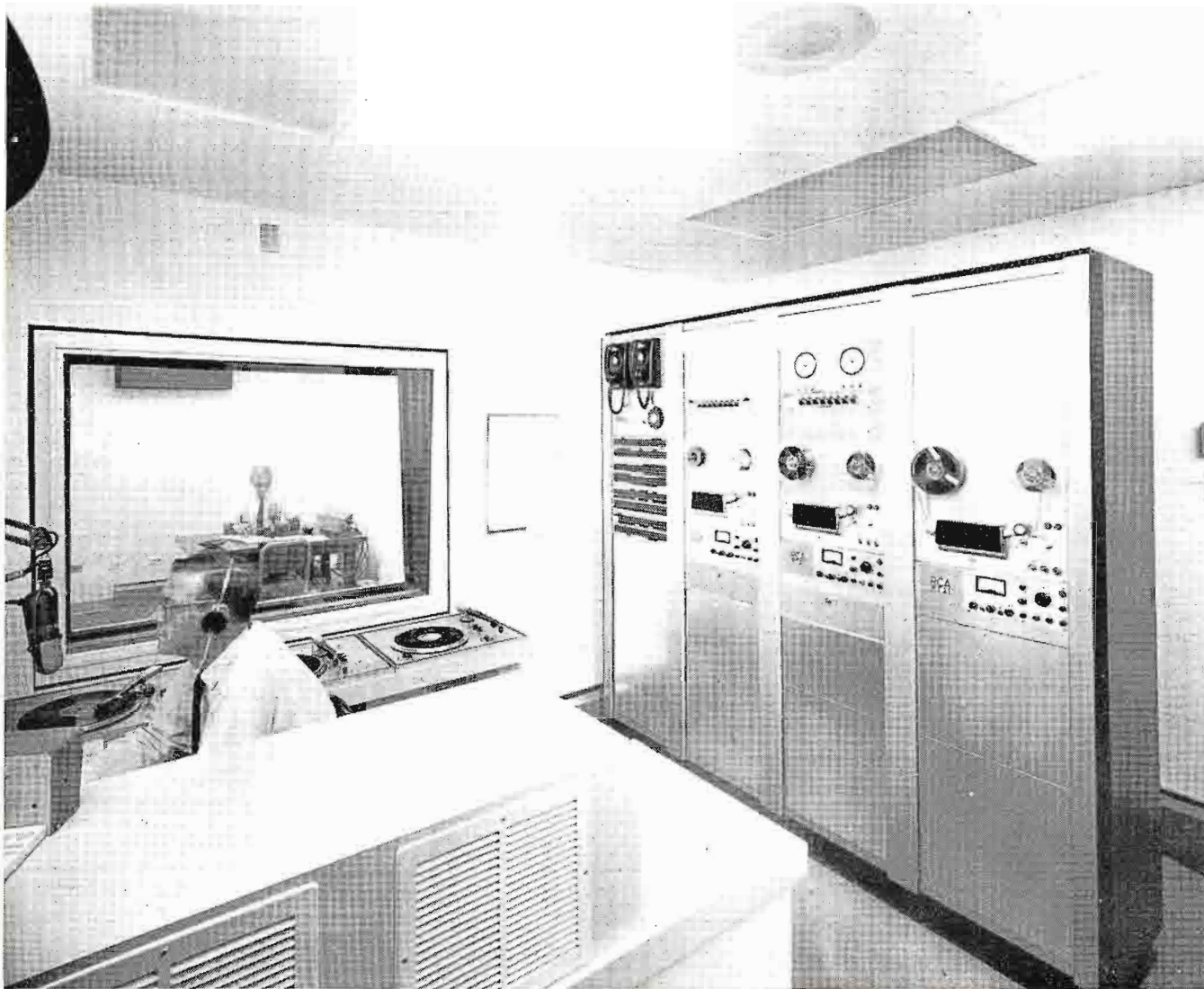

TWO IDENTICAL RADIO CONTROL ROOMS serve the needs of both WSJS-AM and WSJS-FM. Photo, left and below, show details of their clean, comfortable, program-oriented layouts. The same kind of systems concepts as were employed in TV were considered in equipping for radio operations.

For the Audience

The new physical and technical facilities of "Broadcast House" make available the wherewithal to do the kind of radio and television programming that represents our basic operational philosophy. "To provide worthwhile radio and television fare—a proper balance of entertainment, information and education—for the people in the WSJS area."

AM and FM Radio

WSJS Radio dates back to 1930. It has grown from a small 100-Watt operation to a regional station operating full-time at 5,000 Watts. It moved along with television to its present location in "Broadcast House" in 1966.

The radio portion of "Broadcast House" features two radio control complexes of a control room and studio. Each complex is identically equipped, thus providing a highly flexible operation for broadcasting and production work. Two television studios can be made available for orchestras, choruses and other larger radio program groups. Equipment includes six transcription turntables, eight reel-to-reel tape recorders, six cartridge tape recorders and two of the latest design dual-channel consolettes.

Easy-to-listen-to popular music keyed to adults, and an emphasis on local news and public service characterizes the programming of WSJS-AM. WSJS-FM, offering a distinct and separate service features the better popular, semi-classical and classical music.



KENTUCKY EDUCATIONAL TELEVISION

Nation's Largest
State Network

Someone once said: The difficult we can do immediately; the impossible takes a little longer. For the educators and schools of Kentucky, their "impossible dream" of a state ETV network did take a little longer, but became a reality on September 22, 1967. On that date the Commonwealth of Kentucky announced it had awarded RCA more than \$4,000,000 in contracts to supply complete UHF television transmitting equipment for 12 broadcasting locations in the state. An ETV network was born.

Prior to that simple September announcement lay years of hard and dedicated work by many individuals and many Kentucky state associations: educators, school board members, school administrators, PTA's, medical groups, and higher education. But, as the December, 1967 Kentucky School Journal said: "The thread that ran through the entire development period, and made the successes exceed the failures, was named O. Leonard Press (Executive Director of the Kentucky ETV Authority) . . . It was the soft voice and quiet determination of "Len" Press that made things happen properly."

Indispensable also throughout the long planning stages was Ronald B. Stewart, Engineering Director of the Authority. It was "Ron" who designed the technical aspects of the transmitting and studio facilities for the state network to insure that practically every school would be within reach of a good signal.

As far back as 1953 when the University of Houston placed the first educational station on the air, there was talk of ETV stations in Kentucky, and even intimations of an eventual state network. When WFPK, Louisville, went on the air in September of 1958, the ETV movement was on.

"You design it," Press said to Stewart, "and I'll try to figure out how we make it come to pass." Into the design went many considerations: first, of course, how to get total state coverage without leaving out the re-



Many talked about it, but O. Leonard Press, executive director of the Kentucky ETV Authority, was the man who did something about getting a statewide ETV network.

For seven years he headed the UK Radio-TV-Films Department, and for a short time was a key official in the ETV division of the Department of Health, Education and Welfare. Even before he became director of the Kentucky program, he set up the original plans and drafted much of the enabling legislation as a "moonlighting" project.



All design work dealing with the technical aspects of Kentucky's 12-transmitter ETV network came from the drawing board of Ronald B. Stewart.

An electrical engineering graduate of UK, he has worked in the UK Radio-TV-Films department, and was chief engineer of a Lexington radio station.

An early planner in the Kentucky ETV project, he began working on it five years before formally joining the authority staff in 1962.

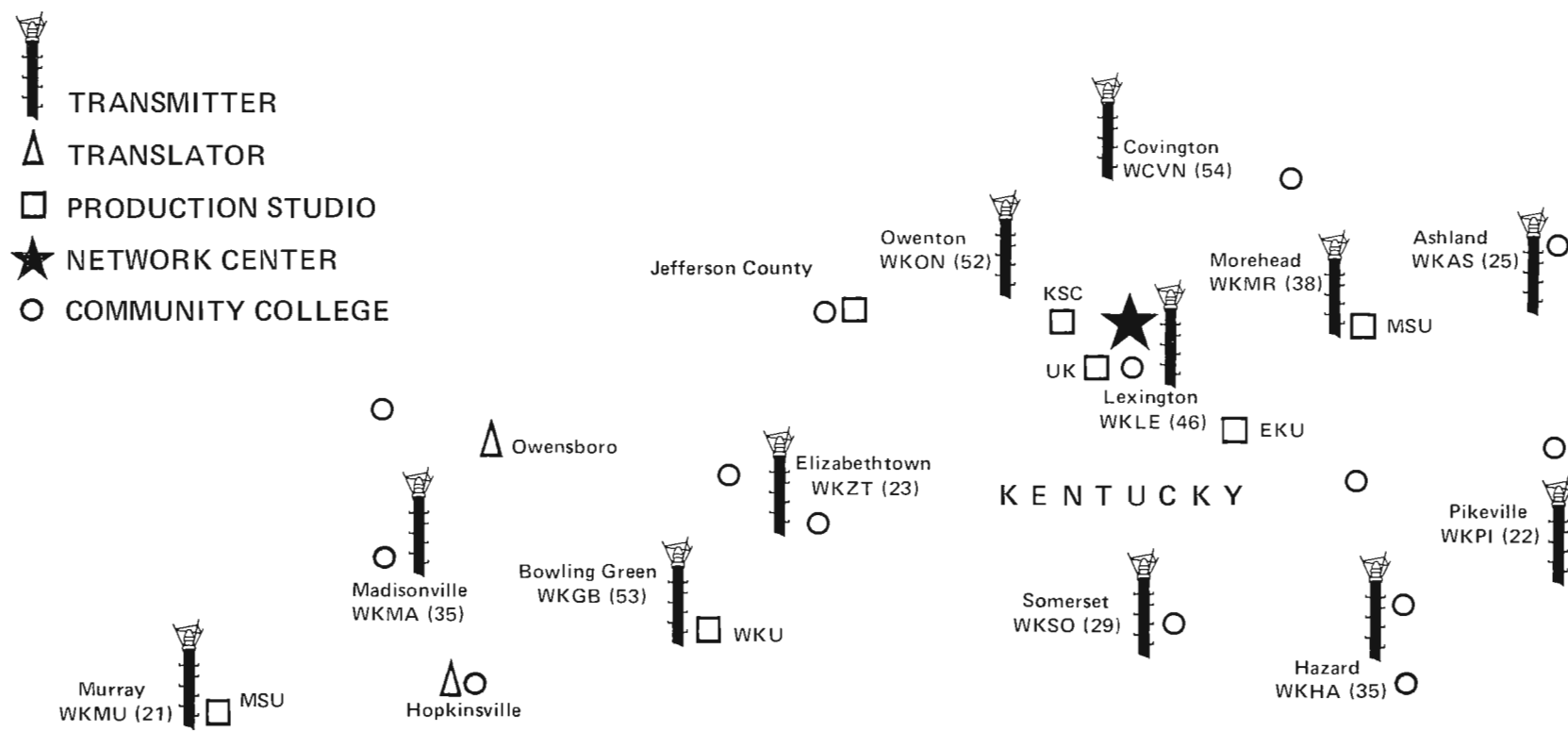

mote areas which needed it most; how to regionalize the network so that unique needs of one area could be met while another area received something else; how to adjust for the multiple time zones of Kentucky (at that time there were at least four from mid-spring to mid-fall); how to tap all educational and program resources in the state; and most important of all, how to involve the schools and colleges so they would look on this new machine as a natural, desirable, progressive extension of their educational program rather than as an unsettling threat to their way of life.

The system went through many design changes from then till now. As a matter of fact, changes in design stopped only when construction began. And even that isn't strictly accurate. Modification continues with construction.

Along the way, various approaches were considered including total closed circuit, multiple-channel open circuit, and a combination of these two. The combination won out. A difficult early decision was whether to have the state build its own microwave system or to lease the service from the telephone company. The common carrier route was finally chosen.

The first positive steps toward a network were taken in 1960 when the Kentucky General Assembly passed a resolution directing the Legislative Research Commission to "conduct a full study of the use of educational television in the Commonwealth." That study was completed in October, 1961 and formed the basis of later legislative action by the General Assembly in 1962.

That Assembly passed three bills: authorizing the State Board of Education to lease educational television facilities from the Kentucky Property and Building Commission; enabling that same Commission to issue revenue bonds for the purpose of constructing ETV facilities; and establishing the Kentucky Authority for Educational Television, a public agency and instrumentality of the Commonwealth, which will operate these facilities by contract with the State Board of Education.



FIG. 1 Shown discussing the ETV network are Don Bale, State Dept. of Education; Roy Owsley, Chairman, Kentucky Authority for ETV; O. Leonard Press, Executive Director; and Wendell Butler, State Superintendent of Public Instruction.

This legislation provided the means, but not the money, for financing construction of the network. It did provide sufficient funds to enable the Authority to hire its core executive staff in 1963. That staff included Press who resigned as Vice Chairman of the nine man Authority and left his university post to become executive director, and Stewart who resigned from the university to become network director of engineering.

With this action, the second step on the way to a network was taken. But, problems still lay ahead. The original plans called for operation to start in the Fall of 1964, but construction problems arose which would delay the start considerably. Then a further major delay occurred due to an unusually tight budget situation in the state. From 1963, the story is probably typical in its ups and downs, political slips between the cup and the lip, money promised but undelivered because preconditions could not be met, some small resistance to change on the part of school people—but let it be noted prominently that there was much less of this in Kentucky than reported elsewhere. It all added up to the “impossible” taking a little longer to achieve.

However, as the months went on, so did the planning. Land sites (some of which were donated) for the transmitters had to be obtained. Channel allocations were received from the FCC. Individuals and groups throughout the state were actively engaged with the legislators urging activation of the network. It seemed almost everyone was behind the movement.

It was in the Fall of 1967 that the third and crucial step was taken when an \$8,600,000 bond issue was passed. With this sum, plus \$1,100,000 from the federal ETV Facilities Act and \$1,140,000 from the Appalachian Redevelopment Act, the nation's largest state network was finally underway.

As part of Kentucky's long range program, the finest of high quality UHF transmitters, identical to those used by major commercial stations, were speci-

fied. These will be placed in 12 locations in the state. Ten of these will be the RCA TTU-30A, a high power transmitter with a rated power output of 30 KW visual. The TTU-30A is economical and easy to operate, and features an integral-cavity vapor cooled klystron, solid state circuitry, and built-in provisions for remote control. Although it is physically small in size, the human engineering designed into it makes for maximum accessibility and simplicity of maintenance. If desired in the future it can be modified up to 50KW in the field.

TTU-2A's will be used in Covington and Ashland, both located on the eastern border of Kentucky, to give better coverage in these mountainous areas. This compact, air-cooled transmitter is rated at 2KW visual output but when used with a standard UHF antenna, is capable of delivering up to 50KW erp. If greater power is needed in the future, this transmitter can serve as the basic driver section of a more powerful 10KW UHF transmitter by adding PA stages and related power handling equipment.

The UHF Pylon antennas specified—ten TFU-30J's and two TFU-6J's—are the types used by the majority of all UHF stations. A major feature of these antennas is that the functions of radiator and supporting structure are combined in one heavy duty slotted cylinder. In these unique antennas, each characteristic desired—gain, vertical pattern, beam tilt, horizontal pattern, impedance and power rating—is an independent parameter which can be controlled, without compromise, to give the optimum performance desired. They are simply but ruggedly constructed to withstand all types of weather conditions.

The network can be segmented into five separate regional feeds. It has a closed circuit component that connects all the state's two and four year colleges plus Kentucky's pioneer ETV station owned and operated by the Jefferson County School Board. There is or will be a production return from each of the four year institutions and Jefferson County, and each of

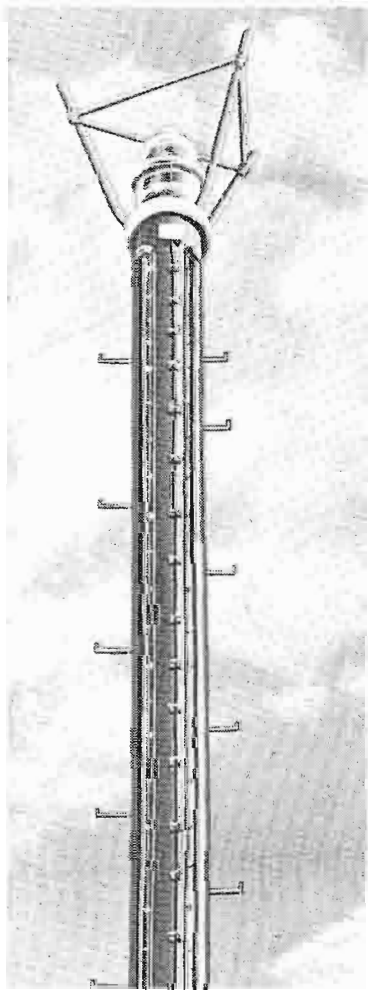

FIG. 2 UHF Pylon antennas are used at all twelve transmitting sites.

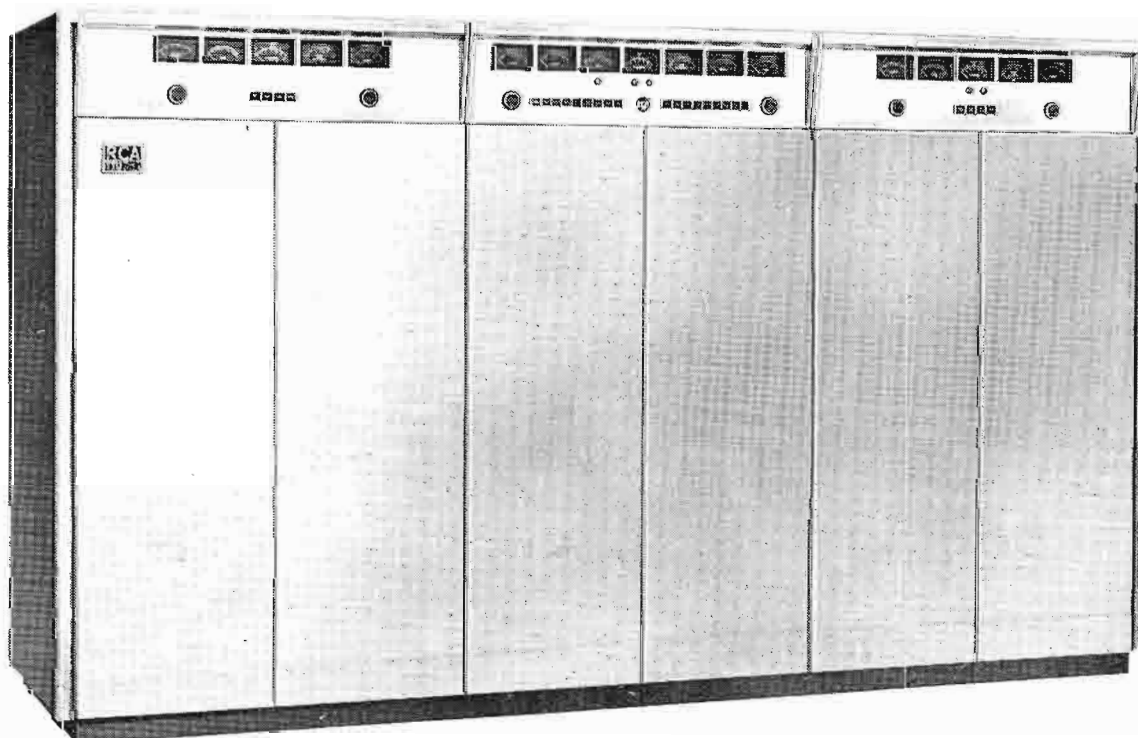

FIG. 3 Ten 30kW TTU-30A transmitters, strategically located, assure a high quality signal to practically every school in the state.

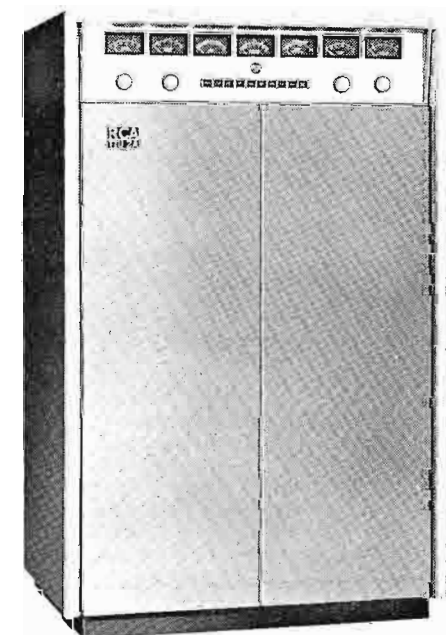

FIG. 4 TTU-2A (2kW) transmitters are located in Covington and Ashland to give better coverage in the eastern mountainous areas.

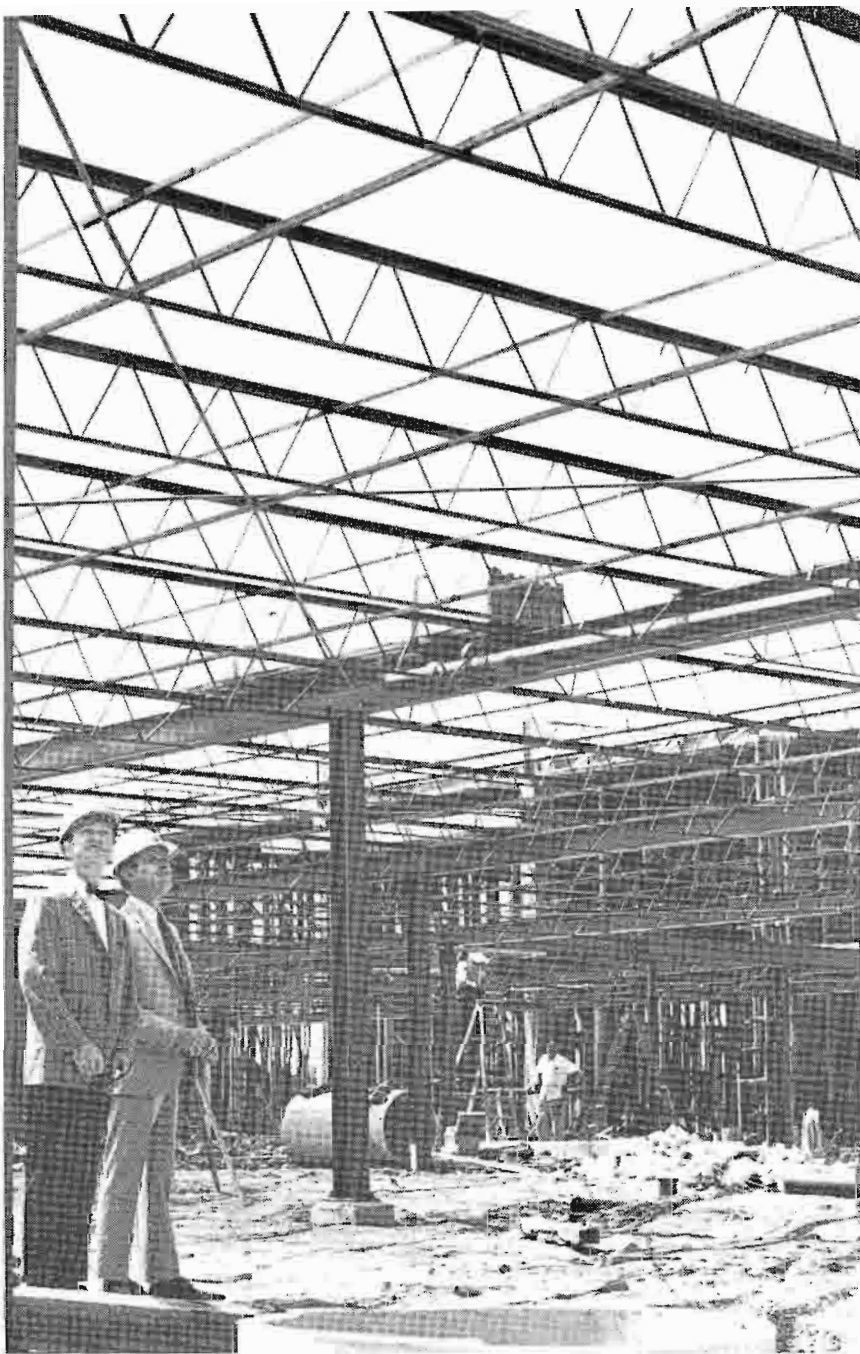

FIG. 5 Len Press and Ron Stewart check on construction of one of the many new buildings required by the network.

these seven institutions has been or will be given \$200,000 worth of studio equipment by the Authority. The conditions are that each provide a suitable studio and an adequate staff, both conditions subject to approval by the Authority staff. The purpose is to assure first class facilities at each institution. The use they are to make of the facilities is up to each but service to the campus and to the training of future teachers was uppermost in the minds of the Authority. Inter-institutional exchange is also a high priority purpose. The studios will also originate some programs for part or all of the network.

The Kentucky ETV network has a first and absolute commitment—aid to the classroom teacher. Educational programs for the network will concentrate for the most part on the elementary and secondary school levels. There will be a full schedule of daytime programs for the pre-schooler and for all grade levels in subjects for which support is critically needed—science, social studies, foreign languages, music, art, literature, history and government.

Late afternoon programs will include college credit courses and professional continuing education in fields such as medicine, law, and business. There will also be programs in vocational training, literacy training, and employment information. Other areas to be served include health, public safety, and enrichment programs such as serious music and plays, opera, and in-depth reports on national and world affairs.

All costs for programming and transmission will be borne by the state; the individual schools and school



FIG. 6 Even delivering transmitters to some of the sites was a major project, but with the help of a bulldozer the RCA van made the grade.

systems will provide their own antennas, converters, and distribution systems within the schools. The Kentucky ETV Authority has issued guidelines and specifications relating to receiving equipment and will recommend experienced persons and suppliers to act as consultants in any reception problems, especially in the eastern mountainous areas. In some parts of that area, it may be necessary to place the receiving antenna and UHF-VHF converter on the nearest mountain and bring the signal to the schools by cable, or make arrangements with an existing CATV system in the area to do so.

The Kentucky state network and educational program may well be a model for many other states still in the planning stages. It did take longer than expected, but as was recently stated by Len Press: "While we may have been late getting to the launch pad, no state has developed near the thrust—in either reach or performance potential—that we have." Time will undoubtedly prove his statement.

KENTUCKY ETV NETWORK

| Call | Chan. | Location | RCA Type | |
|------|-------|---------------|----------|---------|
| | | | Xmtr. | Antenna |
| WCVN | 54 | Covington | TTU-2A | TFU-6J |
| WKAS | 25 | Ashland | TTU-2A | TFU-6J |
| WKZT | 23 | Elizabethtown | TTU-30A | TFU-30J |
| WKGB | 53 | Bowling Green | TTU-30A | TFU-30J |
| WKHA | 35 | Hazard | TTU-30A | TFU-30J |
| WKLE | 46 | Lexington | TTU-30A | TFU-30J |
| WKMA | 35 | Madisonville | TTU-30A | TFU-30J |
| WKMR | 38 | Morehead | TTU-30A | TFU-30J |
| WKMU | 21 | Murray | TTU-30A | TFU-30J |
| WKON | 52 | Owenton | TTU-30A | TFU-30J |
| WKPI | 22 | Pikeville | TTU-30A | TFU-30J |
| WKSO | 29 | Somerset | TTU-30A | TFU-30J |

FIG. 1 Army Colonel John J. Christy, DINFOS Commandant, takes time out from his busy administrative duties to observe a student telecast from the master control room.

SERVING THE TROOPS OVERSEAS

DINFOS Keeps Home
A Touch of the Dial Away

COLONEL JOHN J. CHRISTY
Commandant, Defense Information School

An infantryman just off a patrol “unwinds” in a sand-bagged bunker by watching “Pa Cartwright, Little Joe, and brother ‘Hoss’” triumph over the bad guys on a portable TV.

Meanwhile, in another area many miles away, a Marine finds time to tune his transistor radio to a uniformed disc jockey playing Lee Hazelwood and Nancy Sinatra’s latest pop hit—the same program that an Air Force flight mechanic is hearing at some Air Base.

Only minutes later, hundreds of miles away on a pitching carrier cruising her way through rough seas, a fighter pilot who just touched down, relaxes and catches up on the homefront news by viewing a telecast from the ship’s own closed-circuit TV station.

Although these scenes may seem paradoxical, they happen every day at military installations, air bases, and ships spread across the globe. Wherever the American serviceman is today, he’s only a touch of the dial away from home.

This global information and education effort is testimony to the importance the U. S. military services place on keeping the American serving overseas completely informed and entertained.

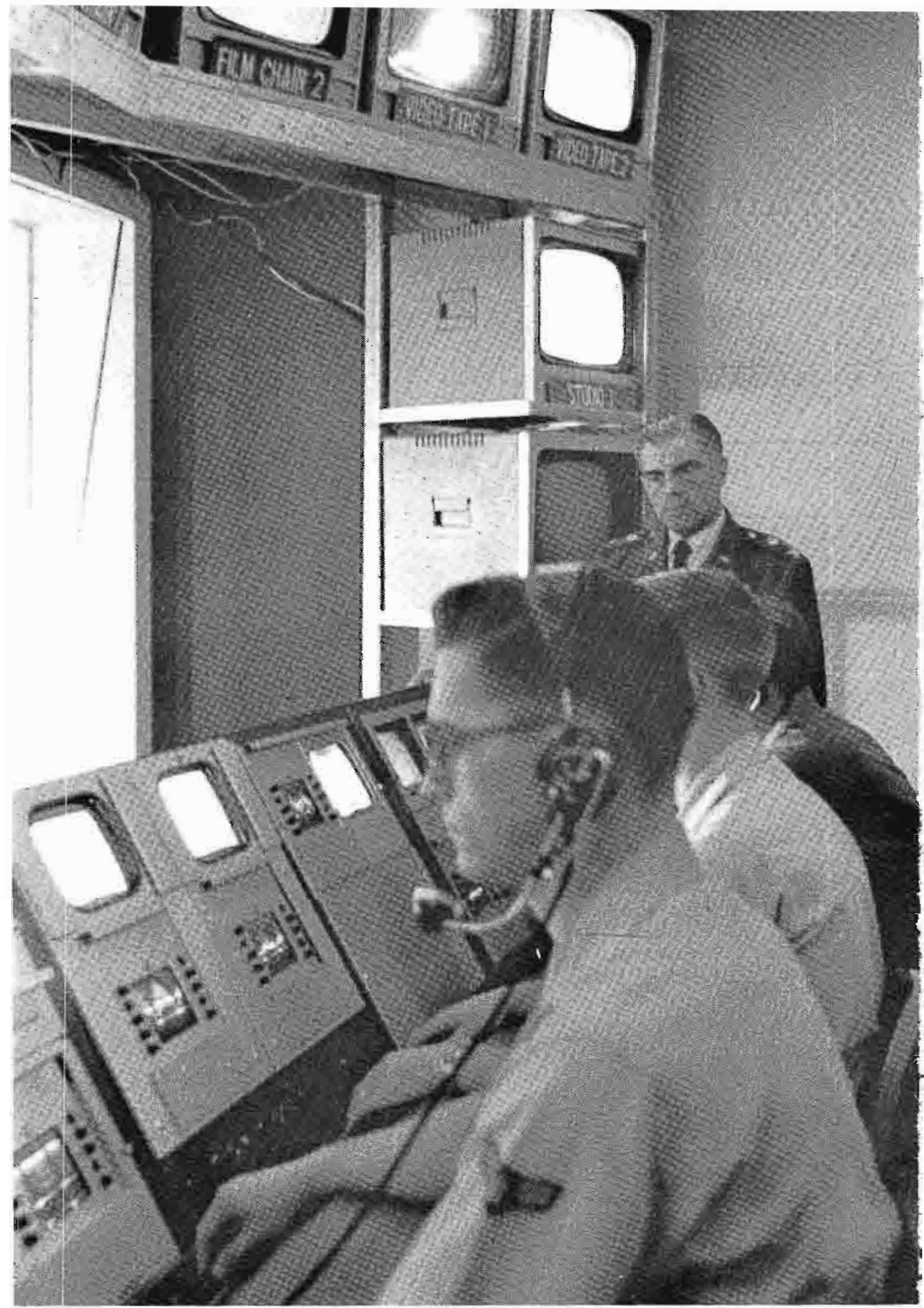

FIG. 2 Airman 3rd Class Jack W. Ernst examines news copy from the teletypewriter at DINFOS where he is a student.

FIG. 3 Navy and Army cameramen, an Air Force stage manager, and a Marine newscaster collaborate on a television newscast.



Today, Department of Defense operates more than 300 radio and 50 television stations to maintain a steady flow of information to the serviceman away from home. The story of how our fighting men and women stay this close to what's happening here at home doesn't start behind the overseas mike or in front of the TV camera; it reaches back to the training these broadcasters, their supervisors and other information personnel receive at the Defense Information School (DINFOS) at Fort Benjamin Harrison, Ind., just outside of Indianapolis.

DINFOS provides a starting point in that much of the manpower for these Armed Forces radio and television stations and those aboard ships at sea, comes from the more than 2,000 military information and broadcast personnel trained at DINFOS last fiscal year (end June 30, 1968). The troop build-up in Southeast Asia has had a dramatic effect on the school and the military information field in general.

Only three short years ago, DINFOS was providing all the military services with only some 800-900 graduates a year. This jumped to 1,800 students trained in FY 1967. We have indications the number will grow to more than 2,500 personnel trained this 1969 fiscal year.

These figures serve to illustrate the commitment that DINFOS and the U. S. military services have to provide highly trained personnel to man the microphones, TV studios, and information offices to keep a

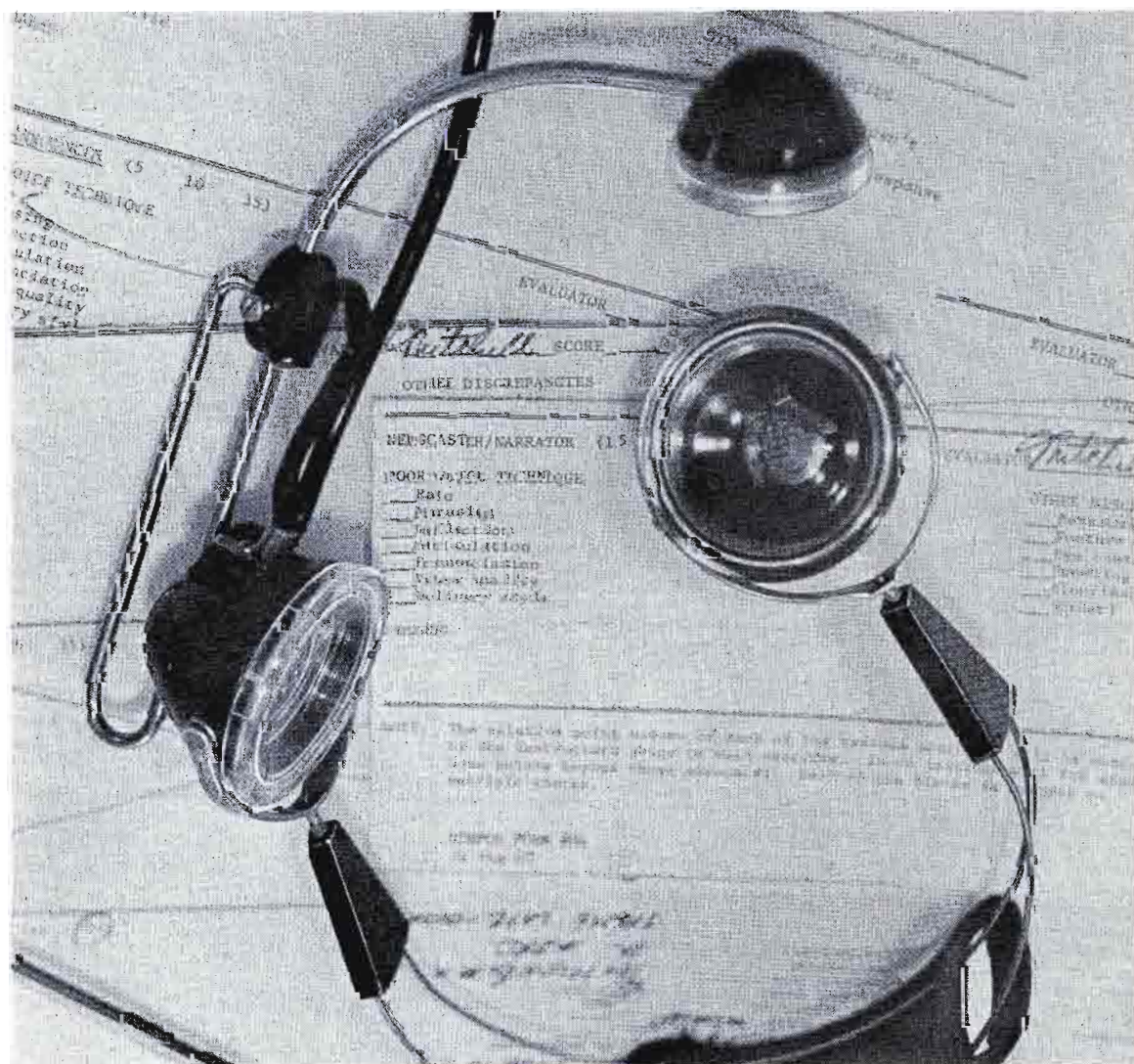

FIG. 4 A headset and grading sheet symbolize the thoroughness and intensity of DINFOS broadcasting training.

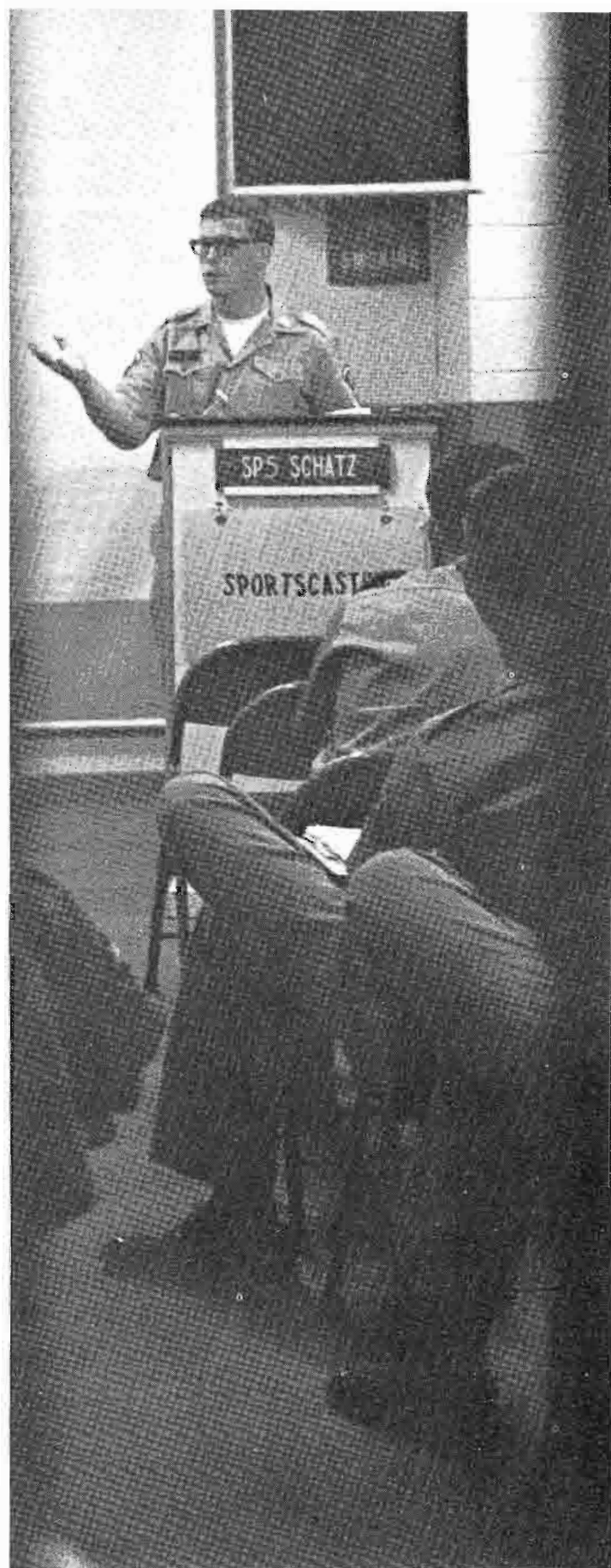

FIG. 5 Army Specialist 5 Roger Schatz, a veteran of Armed Forces Radio Korea Network service, puts his experience to work teaching sportscasting to a Broadcast Specialist Class.

factual flow of information to American troops and the American public.

DINFOS Not New

This is where DINFOS enters the picture. Our mission is to provide the military services with the trained information officers and broadcasters capable of performing in a highly professional manner. The pipeline to the Armed Forces radio and television stations, shipboard radio and TV stations, to military information offices around the world begins at DINFOS.

The school is not new to the business. Although the Defense Information School was founded July 1, 1964, at Fort Slocum, N. Y., the lineage of DINFOS and its predecessor schools goes back to the founding of the first formal military information school, (the Army Information School) at Carlisle Barracks in Pennsylvania, February 1946. DINFOS became a reality when former Secretary of Defense Robert S. McNamara directed that one information school be established, with a joint staff and faculty and respon-

FIG. 6 Seaman David C. Dunbar, USN, student at DINFOS, monitors a music program over closed-circuit radio station, WDIS.



sibility for conducting all information training for the Department of Defense.

As a result, the Army Information School at Fort Slocum and the U. S. Naval School, Journalist, at Great Lakes, Ill., were merged to form DINFOS. The school moved from Fort Slocum to Fort Benjamin Harrison between September and October 1965.

The school's charter charged the Secretary of the Army with the responsibility for operating the school. This responsibility has been further delegated to the Deputy Chief of Staff for Personnel at Department of the Army. DINFOS operates under the policy guidance and supervision of the Assistant Secretaries of Defense for Manpower and Public Affairs, in coordination with the Chiefs and Directors of Information of the military services.

The Department of the Army functions as the executive agency for DINFOS, with an Army officer as the school's commandant. The offices of Assistant Commandant and Director of Instruction alternate between the Navy and the Air Force, giving DINFOS



FIG. 7 An Army student prepares slides for a student newscast in the "new" film chain room. DINFOS recently "modernized" the telecine with two RCA TP-66's. The TK-22 remains a part of the system.



FIG. 8 Students of the three military branches apply their skills to the technical controls of WDIF-TV closed-circuit system.

joint-service representation and continuity at the top executive level.

Professional Faculty

The DINFOS staff and faculty is made up of approximately 162 officers and enlisted men from the Army, Navy, Air Force and Marine Corps, and civilian instructors and staff employees of the Department of the Army. Each is highly skilled and qualified for his particular specialty through civilian and military communications experience or educational background. Many have advanced degrees in journalism, broadcasting, public relations and mass communication. Together they form a dedicated team that might well be the envy of many schools of communication in colleges and universities.

The philosophy of DINFOS is to give the student the maximum of individualized, practical experience possible in the short time available. This is achieved in the Radio and Television Department under the direction of Air Force Lieutenant Colonel Charles A.

Smith, for example, by a student-to-instructor ratio of 4-to-1 in the television section and 6-to-1 in radio.

The same is true in the other two DINFOS academic departments which teach "hard skill subjects": Applied Journalism and Research and Oral Communications. Because of the theoretical nature of the subjects, the two remaining departments, Policy and Plans and International Relations and Government, present the majority of their instruction through conferences and seminars.

Offers Eight Courses

DINFOS presently offers eight regularly scheduled courses varying in length from two to ten weeks. The scope of the particular instruction varies with the objective of the course. These courses are:

- A 10-week Basic Military Journalist Course
- An 8-week Information Officer Basic Course
- An 8-week Broadcast Specialist Course
- An 8-week Advanced Information Specialist Course

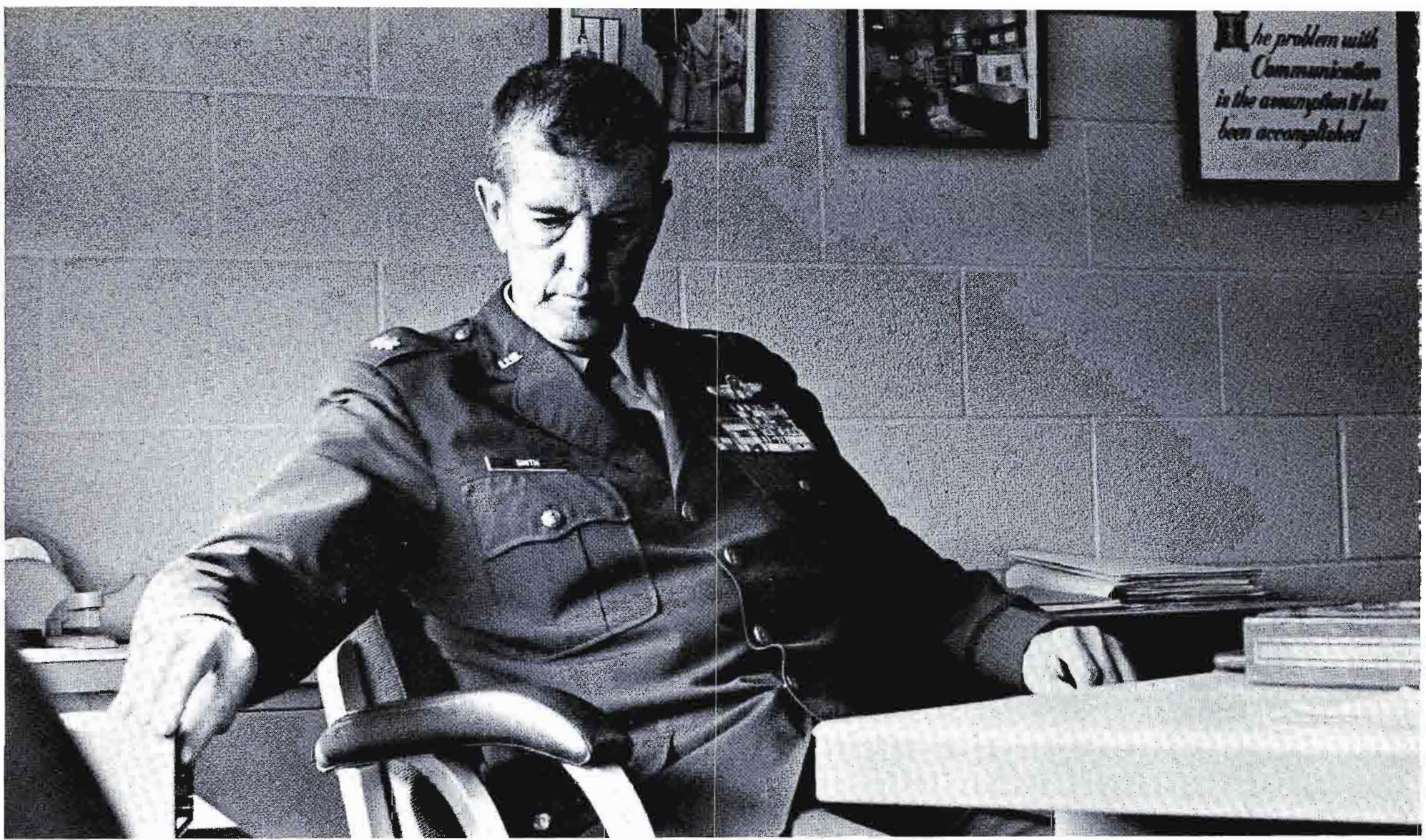

FIG. 9 Air Force Lieutenant Colonel Charles Smith, head of the DINFOS Radio-Television Department, monitors one of the radio control rooms to check the progress of his students.

- A 4-week Broadcast Officer Course
- A 2-week Public Affairs Seminar
- A 3-week Newspaper Editors Course
- A 2-week abbreviated Information Officer Basic Course for reserve officers

The complete course offerings at DINFOS include instruction in all the communications arts and related fields: journalism, broadcasting, effective speaking, military information policy and plans, public relations, community relations, international relations and government.

The courses relating to broadcasting are of prime importance because of the impact of these two powerful media on the servicemen overseas and the public back home.

Although all DINFOS courses, with the exception of the Newspaper Editor's Course, get some broadcasting training, the two DINFOS courses tailored to meet the needs of Armed Forces radio and television stations overseas are the Broadcast Specialist Course and the Broadcast Officer Course.

Trains 500 Broadcasters

The Broadcast Specialist Course, or BSC as we know it, is the prime training vehicle for enlisted broadcasters. Nearly 500 enlisted men from all services received training from this intensified course of instruction last fiscal year. The number of students enrolled in BSC is expected to be even higher this year with 12 classes, in each of which we have some 48 students, scheduled for FY 69.

Although the Broadcast Officer Course or BOC, as it is called, trains but a fraction of the number of students that BSC does, it is nevertheless an important part of the effort to provide broadcast-trained supervisors to military broadcast facilities. While BSC graduates will be the operators, BOC-trained officers



FIG. 10 Probably the most attentive listeners the DINFOS "djs" will ever have are the white-jacketed instructors who monitor and critique the students.

will be the managers who plan, coordinate and supervise station operations around the world.

Students in the BSC course find there's often little "spare" time. Because of the number of students and our space limitations, the BSC radio and television work is double-shifted. The first shift begins at 6 a.m. and ends at 2 p.m. The second shift runs from 2 to 10 p.m. During BSC training, students operate as if they were on actual broadcast facilities—WDIS Radio and WDIS-TV. Although WDIX Radio broadcasts only to the alert ears of the radio instruction group, WDIS-TV can be picked up from monitors located in the offices of major DINFOS staff and faculty members. In this way students know that someone is always watching.

The BSC program of instruction covers all phases of radio and television broadcasting, except skills which involve maintenance and technical engineering which are handled by Chief DINFOS Engineer Dick Cochran.

The "acid test" for the BSC student's radio training comes during the broadcast exercise (BX) when the class is divided into groups of eight students. For two straight, 16-hour days, they act as individual and network Armed Forces radio stations. During the BX, students are strictly "on their own" but still within the watchful ears of their instructors.

Radio Facilities

As a training ground for broadcasters, DINFOS is equipped with a total of eight radio studios, six of which are small control room-announcing booth combinations which are comparable to either an Armed Forces radio outlet or a civilian radio station.

Each master control studio houses a complete complement of broadcast quality equipment: dual channel console, reel and cartridge tape recorders, turntables, microphones, etc. The six small studios have essentially the same type of equipment.

Any of these combinations can be operated independently or together as a network. For network operations, there is a radio control room and the studio, control and announcing booth for large-scale radio production.

Television Facilities

Television training facilities are modern and extensive, with one large production studio which divides into two fully operational studios associated control rooms, film chains, broadcast video tape recorders and a master control room which can combine all operations.

Studio 1 is equipped with professional vidicon cameras and associated equipment. For wider experience with different types of equipment, Studio 2 uses TK-11 and TK-60 image orthicon cameras. Master control has a TS-40 switcher with special effects, a dual channel audio console plus remote controls for all studio cameras, the two TK-22 film chains, and the three TR-4 tape recorders.

A separate equipment room houses all the necessary terminal equipment—output, video and pulse amplifiers, two TG-3 sync generators, test equipment, the TK-22 film camera controls, etc.

Still, equipment—no matter how modern or complete—doesn't make DINFOS the fine training institution it is: Only dedicated and professional staff and faculty members can make this mark.

Team Effort

No matter which service our staff and faculty come from, they are all married to the proposition of turning out the finest graduate possible. Training at DINFOS is a team effort and above inter-service rivalry. It takes the efforts of all uniforms, of all colors, and the professional civilian staff and faculty members to make the DINFOS' "Purple Suit Concept" (a joint military operation) a working reality.

We believe we are providing a valuable service to the men and women in uniform stationed around the globe and also to the commercial and educational broadcasting industries. A by-product of our training is a pool of well-trained and experienced manpower, many of whom enter the commercial and educational broadcasting fields when their service obligations are finished.

Our commitment to the military services, and through them to the men stationed around the world, is to continue to provide the highest quality broadcasters and information personnel possible. To the man in the field, having "home" only a touch of the dial away is tremendously important.

It's just as important to those of us at the Defense Information School.

FIG. 11 The newest edition to the modern facilities at WDIS is an RCA TK-60.

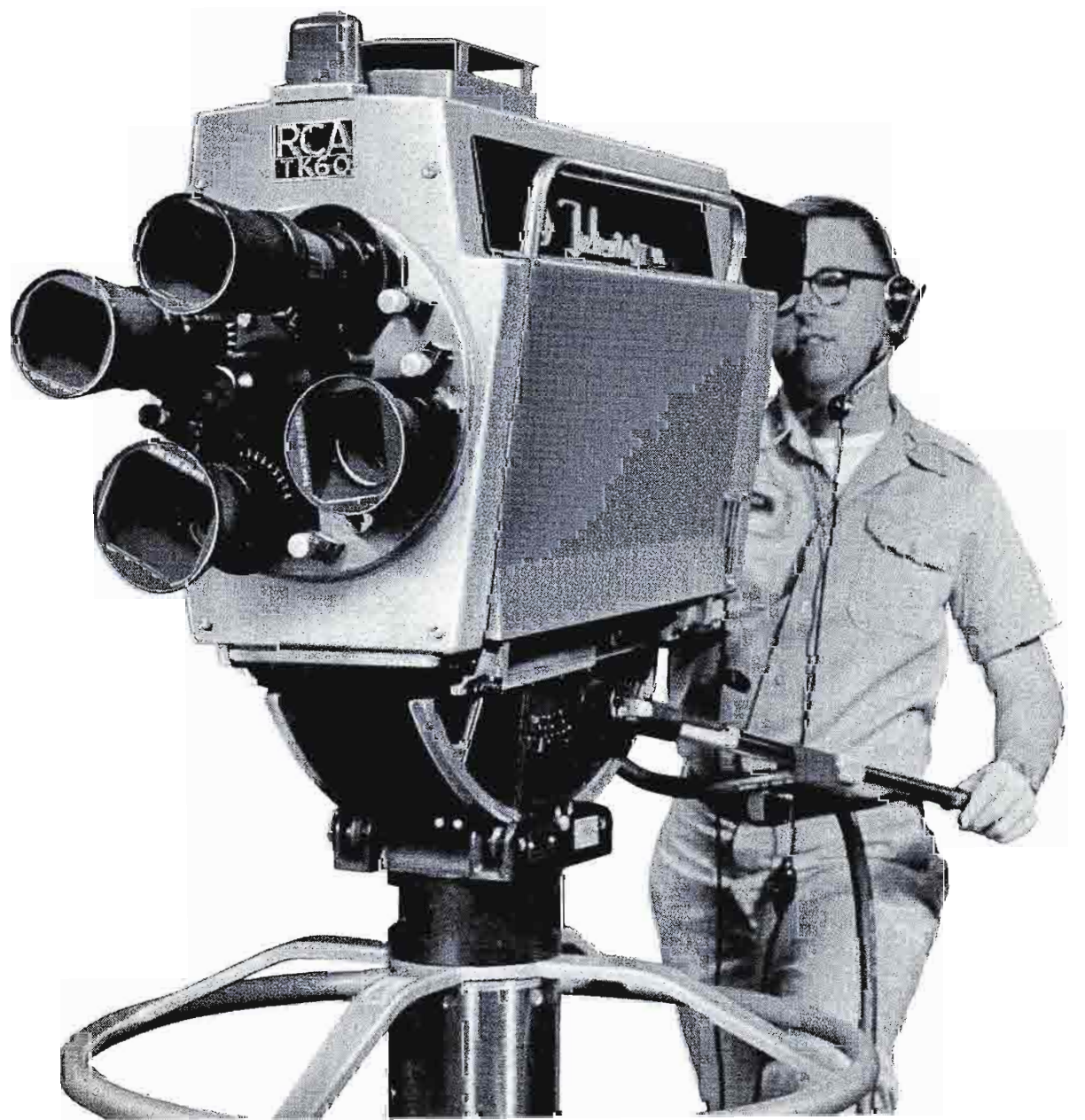

Editing TV Tapes

With the RCA Tape
Editing Programmer



FIG. 1 The Tape Editing Programmer can be used with any RCA highband tape recorder suitably equipped with Electronic Splicer modules.

When video tape was introduced in the late 1950's its major advantages over other recording media were its "like-live" appearance and the immediacy of replay. In the late 1960's, these same advantages keep video tape process ahead of other contenders in the recording field. The introduction of automatic timing control for monochrome and color (ATC and CATC), electronic splicing, highband, and production editing techniques are keeping video tape recording abreast of the industry requirements.

Electronic Finger

It is the area of production editing with which this article deals. RCA has recently introduced the Tape Editing Programmer or TEP. This new equipment is basically a small computer connected to the electronic splicer. (See *BROADCAST NEWS*, Vol. No.

139 for details of the electronic splicing technique.) In effect, the TEP becomes an electronic finger capable of initiating the splice function at any predetermined point.

The heart of the TEP is a system of counters and memories. Simply, a number is stored in a memory during one operation; then, during the next operation, the number stored is compared to a number being counted. When the stored number equals the counted number, a function will be initiated.

Not only is the activation of the splice function important in production editing, but the ability to preview or rehearse a sequence without damaging the original program material is becoming an increasing requirement. The TEP incorporates this preview ability as well as many other facilities to make it a most versatile production tool.

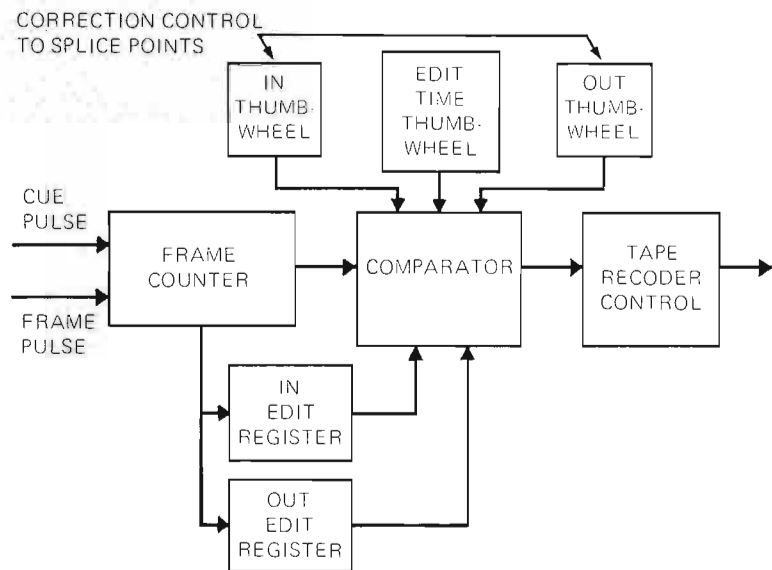

FIG. 2 Simplified block diagram of the TEP system.

Using the Programmer

To better understand the use and operation of TEP, let us consider performing a simple insert splice. We shall assume the material to be inserted into the already recorded material is a slide. The slide insert is to replace another slide on the tape.

The first step is to place the tape machine in the PLAY mode with the Programmer in the SET EDIT mode. About fourteen seconds prior to the anticipated ingoing splice point, the "CUE" button is pushed. This permits a two second tone to be recorded on the cue track. This tone is known as the bench mark. The bench mark on the tape signifies to the electronic circuitry that the counter should begin to count TV frame pulses. At the point where the new slide material is to be inserted, the IN button is pushed. This action electronically transfers the number in the counter to the ingoing splice memory store. The counter continues counting. When the point is reached where the outgoing splice is desired, the OUT button is pushed and the number in the counter is transferred to the outgoing splice memory. Four seconds after the initiation of the "out" splice, the machine automatically rewinds to the previously established bench mark.

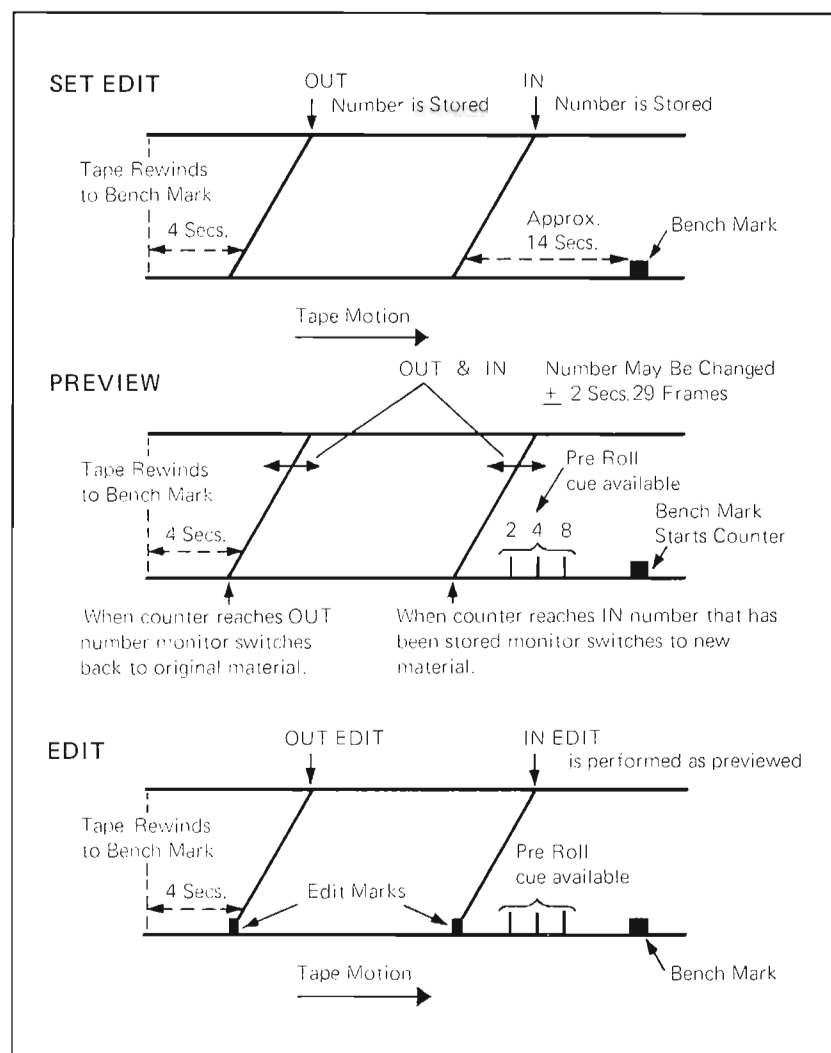

FIG. 3 Steps to be followed in performing a simple insert splice.

FIG. 4 The front panel of TEP chassis showing operating controls.

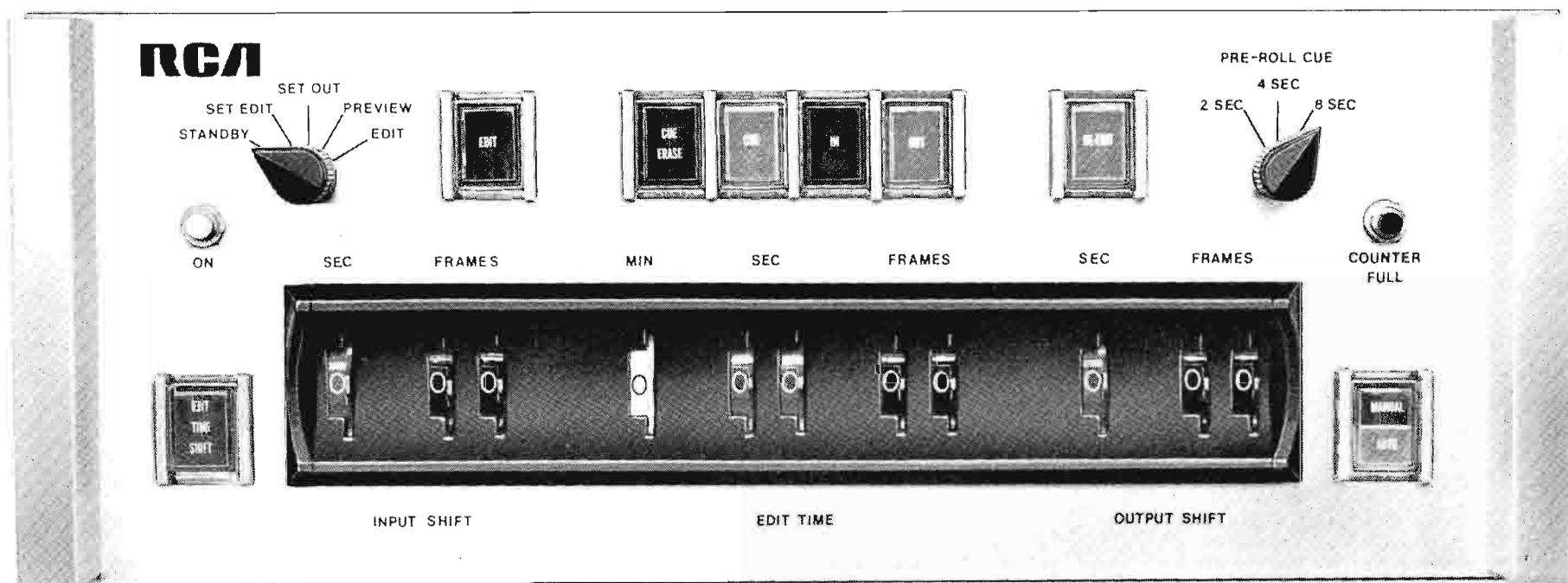
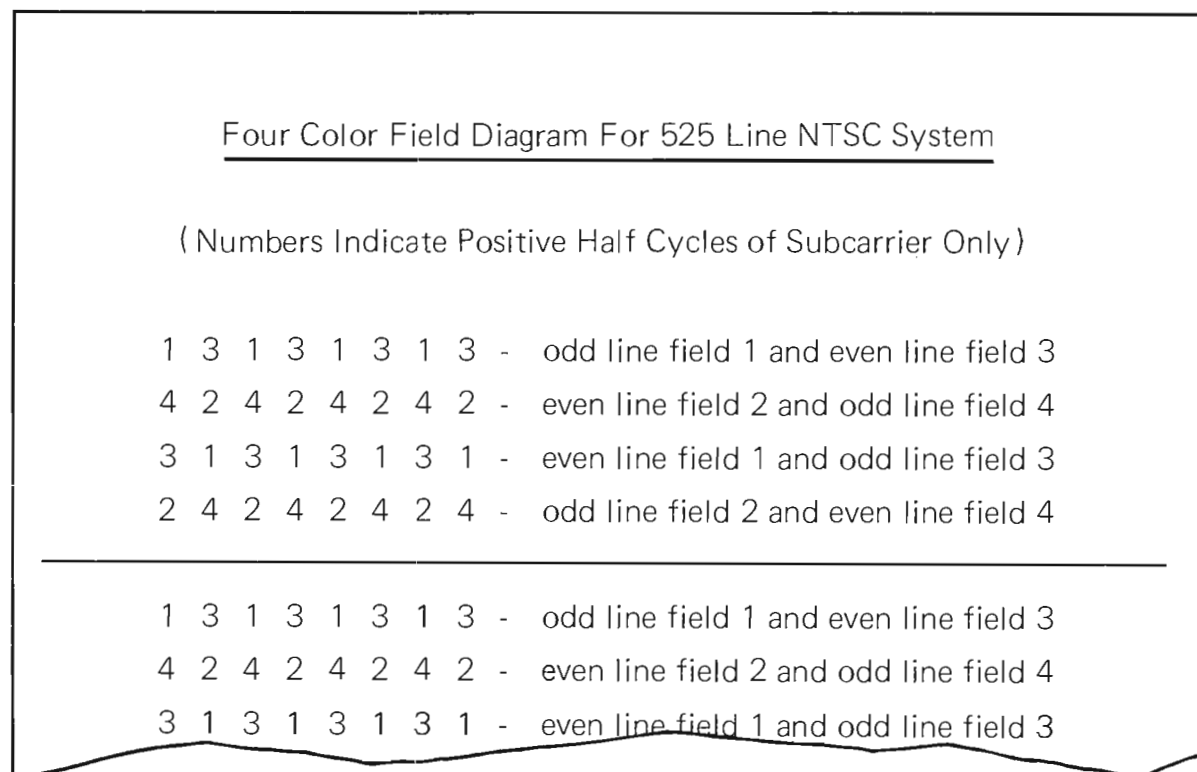

FIG. 5 Diagram illustrating color fields in a 525 line NTSC system.



Preview or Rehearsal

To insure the correct splice points have been established, the splice sequence can now be previewed or rehearsed. The TEP mode selector is placed in the PREVIEW position and the machine PLAY mode initiated.

As the bench mark on the cue track is read off the tape by the normal cue head on the machine, the counter in the Programmer begins counting frame pulses. When the number in the counter matches the number stored in the ingoing memory, the ingoing splice point will be previewed on a monitor as it would appear if the splice were actually being made. Likewise, the outgoing splice point will be viewed on the monitor when the pulses being counted match the number stored in the outgoing memory. Again, the machine rewinds to the bench mark. At this point, none of the original material has been destroyed, yet a complete preview of the spliced sequence has been carried out.

During the process of performing the edits, small edit marks are placed on the cue track. At a later date these edit marks can be used to program TEP in the identical manner as the original program. The mode of operation that recognizes these edit marks is the "re-edit" mode. This mode is more useful when inserted material has to be updated to the same joints as previous material.

Correcting Timing

If either the ingoing or outgoing splice points were incorrect as previewed, it is possible to move either point by up to three seconds in a positive or negative direction (± 3 seconds) in one frame increments. Changing the splice point can be accomplished by dialing in the necessary correction factor with the thumbwheels on the TEP control panel. Once it has

been established that the splice points are in the correct position, it is necessary only to select the EDIT mode on the Programmer. The machine then performs electronically the spliced sequence in accordance with the previously previewed timings.

Add-Ons, Animation and Effects

The sequence of performing a simple insert splice has been described. Other splicing sequences such as add-on edits, edits of a known time duration, edits to the rythm of music on the sound track, edits to construct animation or trick effects, can also be performed.

Machine Control

Not described in our simple insert spliced sequence were the other functions that the TEP performs automatically once the selection of the splice points have been established. For example, cues or a closed set of relay contacts are provided at 8, 4, or 2 seconds prior to the ingoing splice point. The timing of this signal is selectable by a control on the front panel. In addition, a permanent eight second trigger is available for delegation to a slave or second machine. Thus, a second machine can be started precisely eight seconds prior to an ingoing splice. This provision is automatically provided. The operator need only select the "in" and "out" edit points. Placement of accurate timing signals can also be recorded on the second machines where "lip sync" or "jump edits" have to be made. (The term "jump edit" refers to an edit that is being made from one program segment to a similar segment recorded on another tape; usually sound sync is required between the two machines.)

Correct Color Field Editing

When editing very short segments of program material, it is possible to create a non-standard condition

for the tape machine to handle. The color TV signal has some interesting properties, one of which is the relationship between the subcarrier and the horizontal sync. As the subcarrier is an odd multiple of half the line frequency, any one line will contain an integral number of cycles plus half a cycle. Thus, any two complete consecutive lines will contain a complete number of subcarrier cycles.

The adjacent lines in any *field* will contain an out-of-phase dot structure because the positive peaks of the subcarrier on one line will lie directly above the negative peaks on the next. Brought down to the basic fundamentals, it takes four TV fields before the subcarrier completes a complete cycle of repetition. This seems rather remote from a discussion on editing, but it is very relevant when splicing short segments of material close together. As the color TV system has a color field repetition rate of 15 Hz, we must insure that when field one occurs, field two is next and so on through field four. If this is not done, a visible disturbance will be seen. Under normal circumstances, the machine is able to cope with the disturbance if the edits are not too close together, but when the edits are only approximately four to ten frames apart, a subjective hue shift can be seen and in severe cases, the machine could become unstable. The TEP therefore, incorporates circuitry that affords the customer the opportunity to make correct color field edits when he is recording short program segments.

Local and Remote Control

Operationally, the Programmer can be mounted in a control room, editing room or adjacent to a tape machine. Connections between TEP and the tape ma-

chine are made by a multi-conductor cable in a similar way that a TV camera is connected to its control unit. It is, therefore, possible with the use of TEP and remote control panels to conduct an editing session away from the machine. Furthermore, it is possible through quick disconnect plugs to use TEP on any number of suitably harnessed machines thus permitting more flexible scheduling of machines. Any RCA highband tv tape machine equipped with cue channel and electronic splicer can be fitted for TEP.

Integrated-Circuit Design

Apart from its production capability and technical performance, the Programmer has built-in technical reliability through the extensive use of integrated circuits. The 250-plus integrated circuits are all "plug-in" for ease of service if it is ever required. Furthermore, unique digital techniques insure accuracy in every editing sequence.

Also included is circuitry to compensate for differences between 7.5 IPS operation and 15 IPS operation and also the differences that occur between 525 and 625 line operation. Any required changes between these various standards are controlled by the logic of the machine in use.

Up-To-Minute Production Facility

Use of the Tape Editing Programmer extends the production capability of video tape recorders to a point where they are truly competitive with the film media. The combination of a video tape recorder equipped with a TEP, a studio mixer with effects mixer and chroma key, provide a studio with unique and creative tape production facilities.

FIG. 6 The Programmer is shown used near the editing recorder. It may also be located remotely.



FIG. 7 More than 250 "plug-in" integrated circuits are employed in the Programmer.

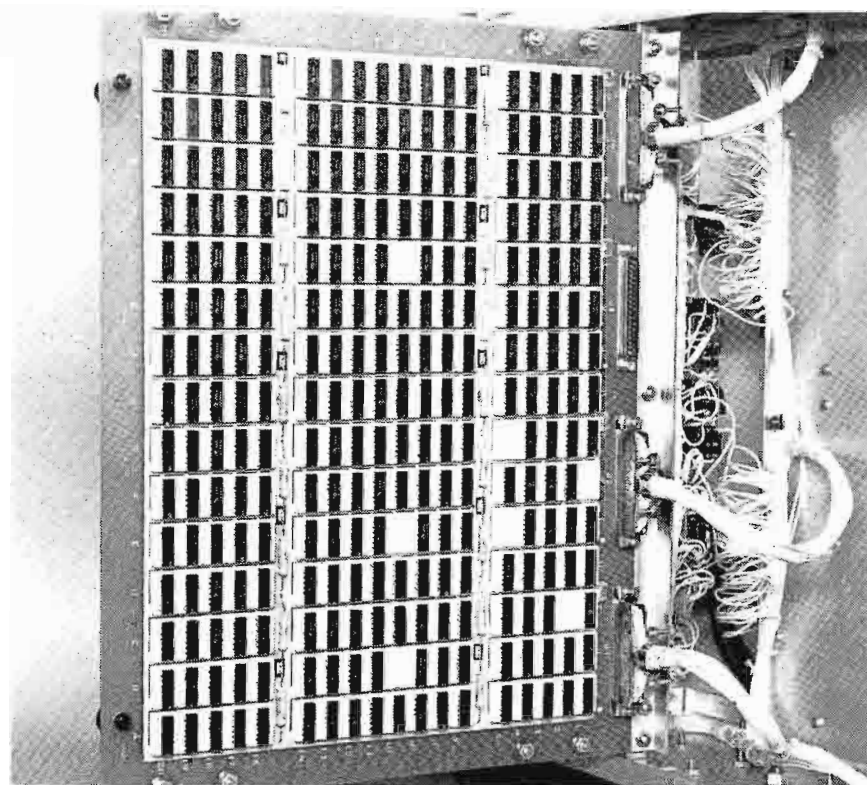

Tube Camera TK-42

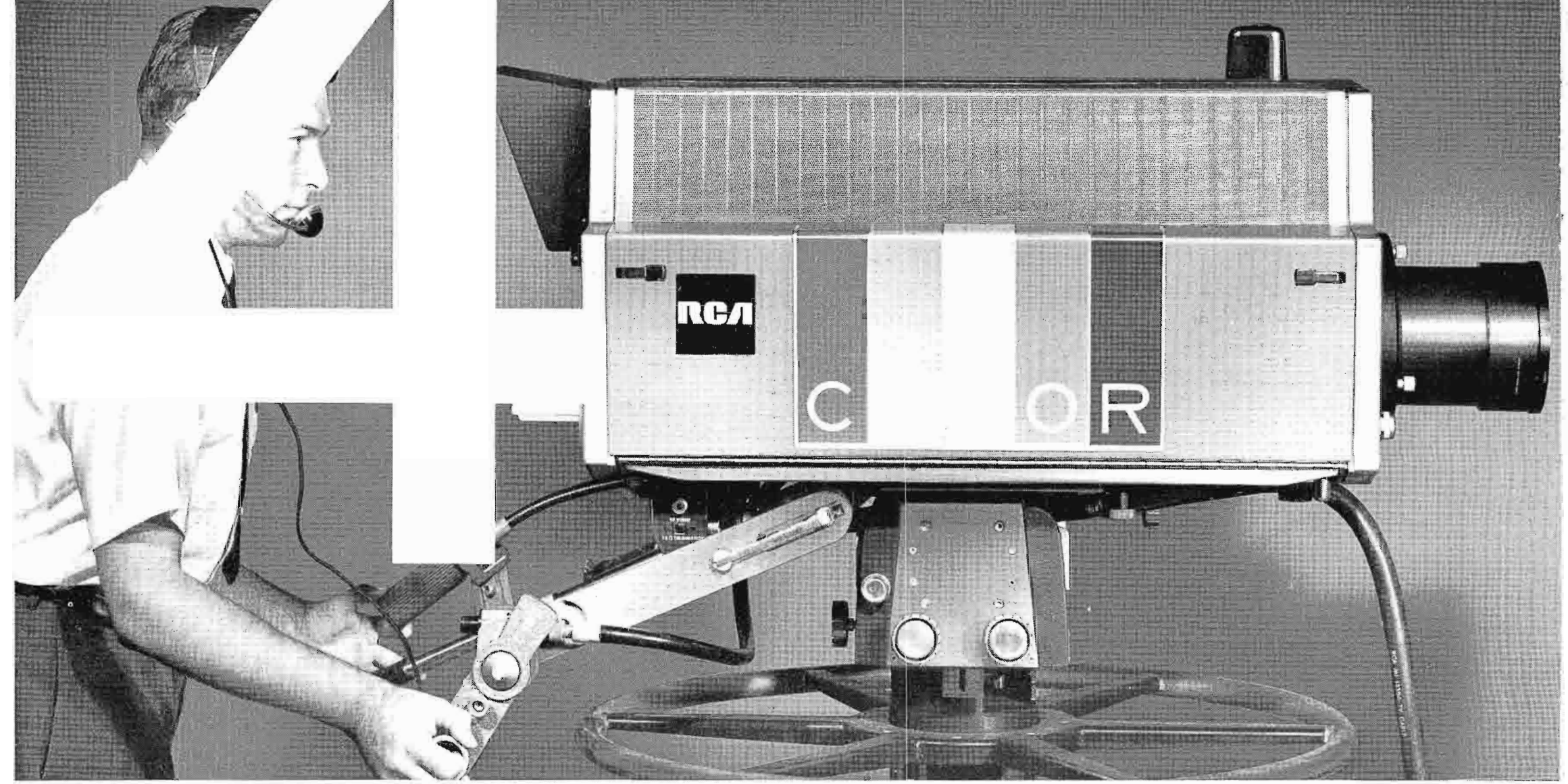

Tube Camera TK-44A

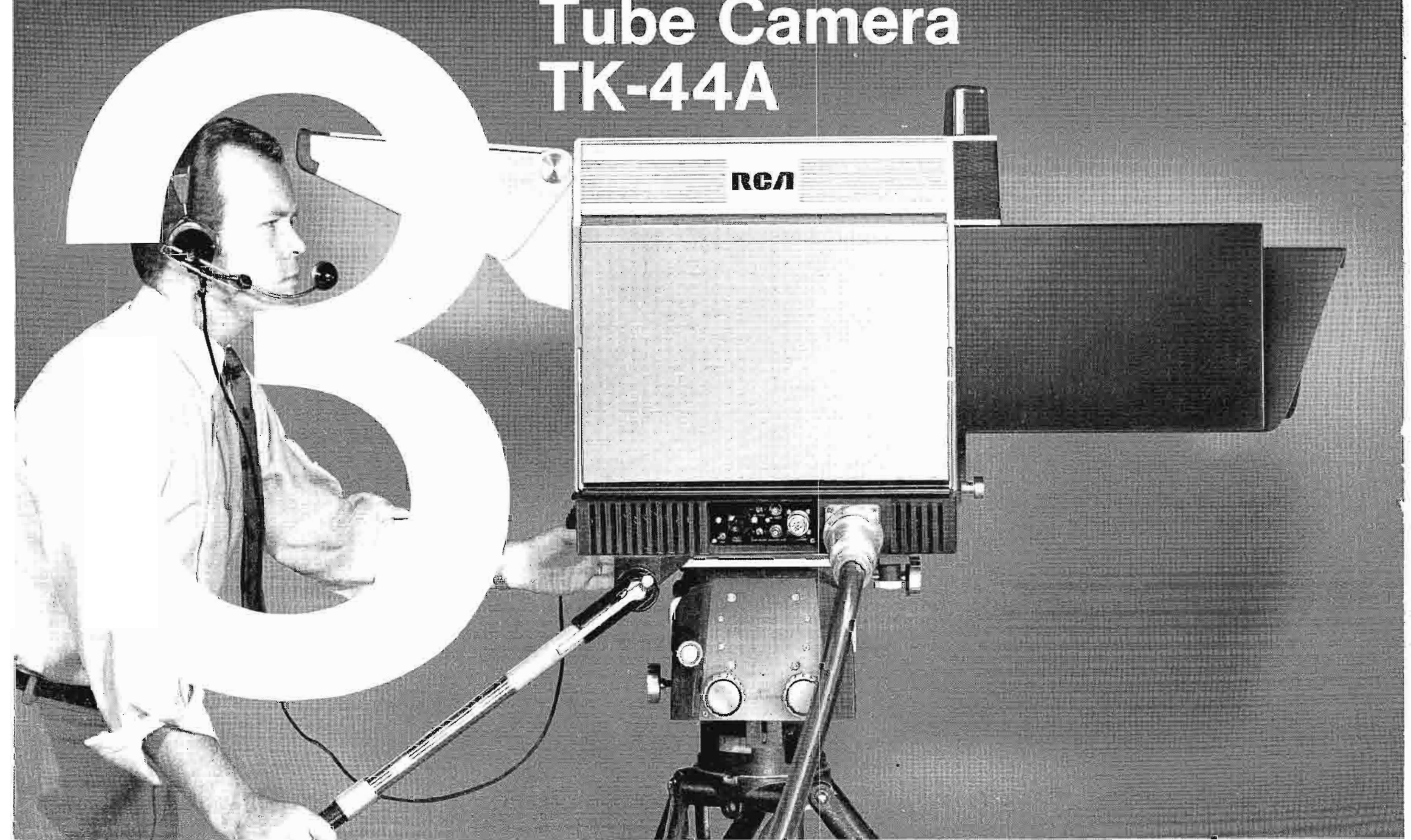

at RCA...you choose the Color Camera

The TK-42 "Best of the 4-Tube Cameras"
now shares honors with the new
TK-44A "Best of the 3-Tube Cameras"

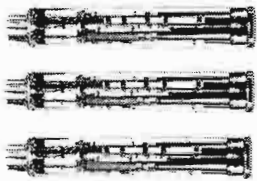
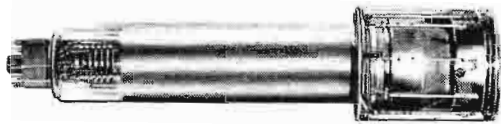

4½-inch I.O. in luminance
channel; three vidicons in
chrominance channels

Two different worlds of design are represented by these two different RCA color cameras.

The TK-42 is the 4-tube design, and the only one employing a 4½-inch image orthicon for resolution unequalled by any 4-tube camera . . . and sharpest color pictures. With a high degree of technical sophistication, the TK-42 has earned the reputation for producing the very finest of color pictures.



three lead oxide tubes
in color channels

The TK-44A is the latest in 3-tube design employing lead oxide tubes. It's especially useful where a lightweight, easy-to-handle camera with high color performance is required. With its many engineering innovations, it produces pictures that are sharper and more detailed than those of any other 3-tube camera.

These RCA cameras can easily be color matched to work together in color productions. Furthermore, they will function beautifully in a total system of RCA broadcast equipment that is matched in design and performance to create an image of highest quality for broadcast stations.

For further information on these cameras, contact your RCA Broadcast Representative or write: RCA Broadcast Equipment, Bldg. 15-5, Camden, N.J. 08102.

RCA Broadcast
Equipment



TELEVISION COMES TO TIERRA DEL FUEGO

FIG. 1 Ushuaia.





FIG. 2 Rio Grande.

This is the story of the installation of the two southernmost television stations in the world, now operating in Tierra Del Fuego, a desolate, dramatically beautiful land, whose monotonously arduous climate makes daily life a real adventure.

An Isolated Land

Tierra Del Fuego is an archipelago at the southern extremity of South America, separated from the mainland by the Straits of Magellan. The famed navigator, as he sailed through the strait in 1520, noticed fires burning on the shores and dubbed the area "land of fire". In shape, the main island is a triangle with its base on Beagle Channel. The total area is 27,476 square miles, about two-thirds of which is Chilean and one-third Argentinian. The Chilean sector is known as the Tierra Del Fuego department of Magellanes Province; the Eastern, Argentine, side is the Governorship of Tierra Del Fuego, where this story took place. Porvenir on Magellan's Strait is the main Chilean town and Ushuaia on Beagle Channel, is the Argentine capital, the southernmost city in the world, a scant 600 miles from the Antarctic Continent.



FIG. 3 Ushuaia Station.



FIG. 4 Rio Grande Station.

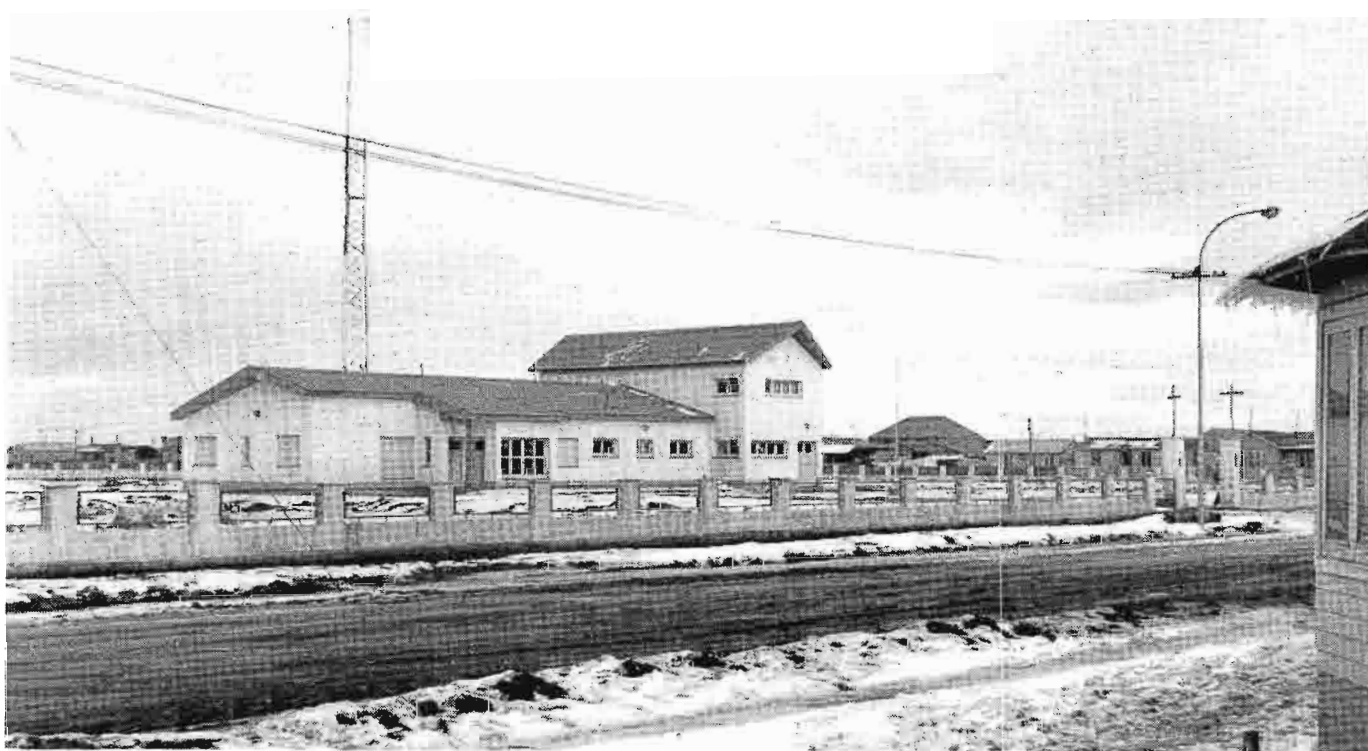

LU 87, TV Channel 11, is located in Ushuaia and LU 88, TV Channel 13, in Rio Grande, the second largest city, situated on the east coast, facing the Atlantic Ocean. It is very difficult in winter to reach either city by land, due to extremely heavy snows. Transportation is either by steamer or airplane, providing the unpaved airport runways are not frozen. The steamer is an Argentine Navy vessel that tries to make monthly roundtrips, but sometimes delays up to 45 days between voyages are encountered.

The combined population of Ushuaia and Rio Grande is approximately 10,000, most of them immigrants and their descendants, who were attracted to the land by the pastoral industry, the gold rush in the 1890s and the discovery of petroleum there in 1946.

Why, you may ask, why television for such a relatively few people in such a desolate, isolated area?

The primary aim was to offer the people of the province a source of entertainment, information, and education. Consequently, on December 7, 1965, the Governorship of Tierra Del Fuego, with the support

and approval of the Federal Government of Argentina, outlined the various steps necessary to provide the "fueginos" (name given to the people of the island) with the tremendous intellectual and cultural progress that television offers.

RCA Is Selected

System specifications for two complete television stations were prepared for the Government under the supervision of Commander Marcelo Barbieri and put to public tender.

Rene M. ChiloteGuy, Manager, Engineering Products Division, RCA Victor Argentina, and his staff studied the tender documents and quickly realized that this was the ideal opportunity to demonstrate the installation capability of the company and the performance and reliability of RCA broadcast equipment. Within a few weeks, Osvaldo Casagrande, a member of the engineering staff, was on his way to present the RCA proposal. To reach Tierra Del Fuego, Casagrande first flew to Rio Gallegos, the last large city on the mainland. Due to extremely adverse

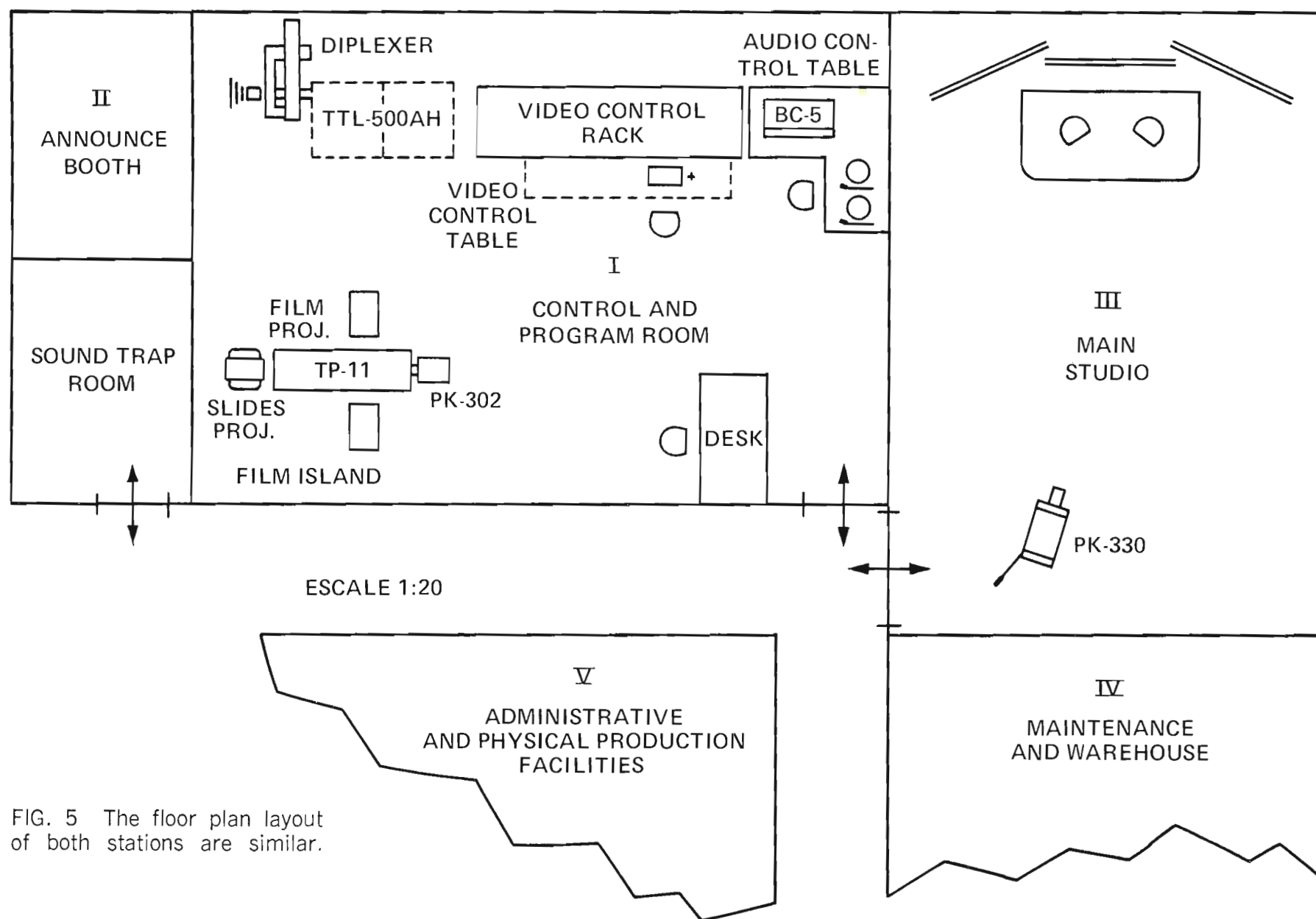

FIG. 5 The floor plan layout of both stations are similar.

weather conditions all commercial flights over the Magellan's Strait to Rio Grande had been cancelled, but as the deadline for presentation of proposals was imminent, Casagrande searched Rio Gallegos for the entire morning and finally was able to persuade a private pilot to attempt the flight.

Although it was the end of November and normally spring for the area, their flight in a two-seater Piper Cub, took place during a howling blizzard with practically zero visibility. Strong gusts eventually pushed them off their course and they drifted over the ocean, where there was no place to land. Fortunately, through a hole in the cloud cover, they were able to recognize the landmark of San Sebastian and resumed their proper heading. Finally, they landed in Rio Grande, where Casagrande made arrangements to continue his flight to Ushuaia via an Argentine Navy C-47 cargo plane. He presented the RCA proposal, which was favorably received and which resulted in an order, the contract for which was signed by Eduardo Stanga on behalf of RCA Victor Argentina in February, 1966.

The Stations

Both stations are quite similar, each being housed in an L-shaped concrete block structure, with the base of the "L" being of two-story design. Channel 11 in Ushuaia is built on a low stone hill some 1000 meters from the center of the city. Channel 13 in Rio Grande is almost in the geographical center of that city. The floor plan of each station is simple and functional, being divided into six sections:

- I) Control and program room (also houses transmitter)
- II) Announce booth
- III) Main studio
- IV) Maintenance and warehouse
- V) Administrative and physical production facilities
- VI) Living quarters for the Chief Engineer and his family

Erection of the buildings commenced during the spring of 1966, September in the southern hemisphere. Access roads to the Ushuaia station had to be constructed—they were blasted out of the island with

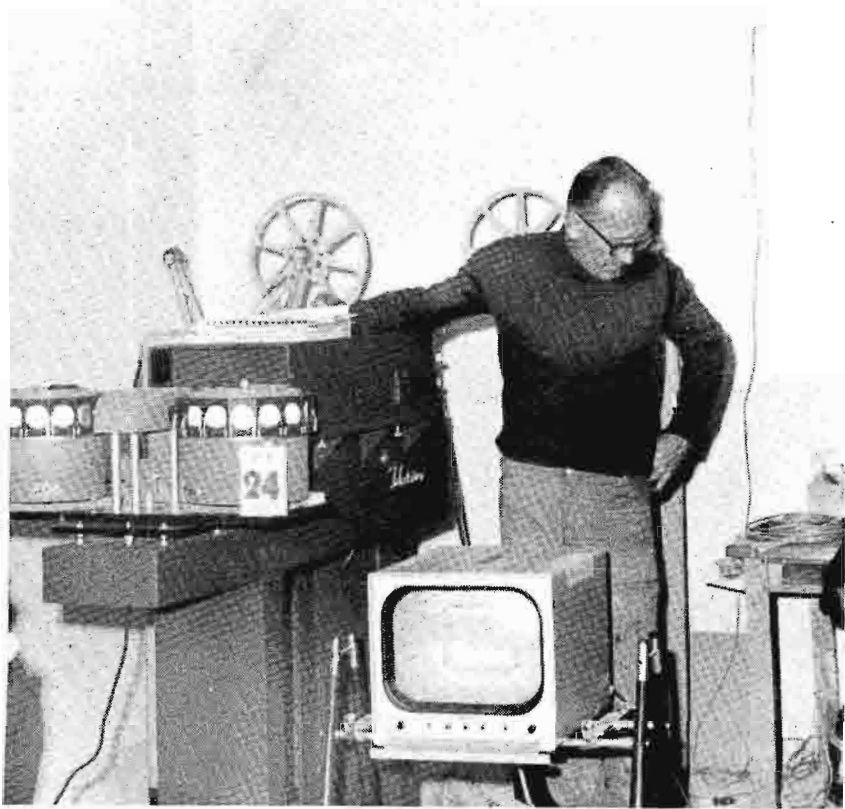
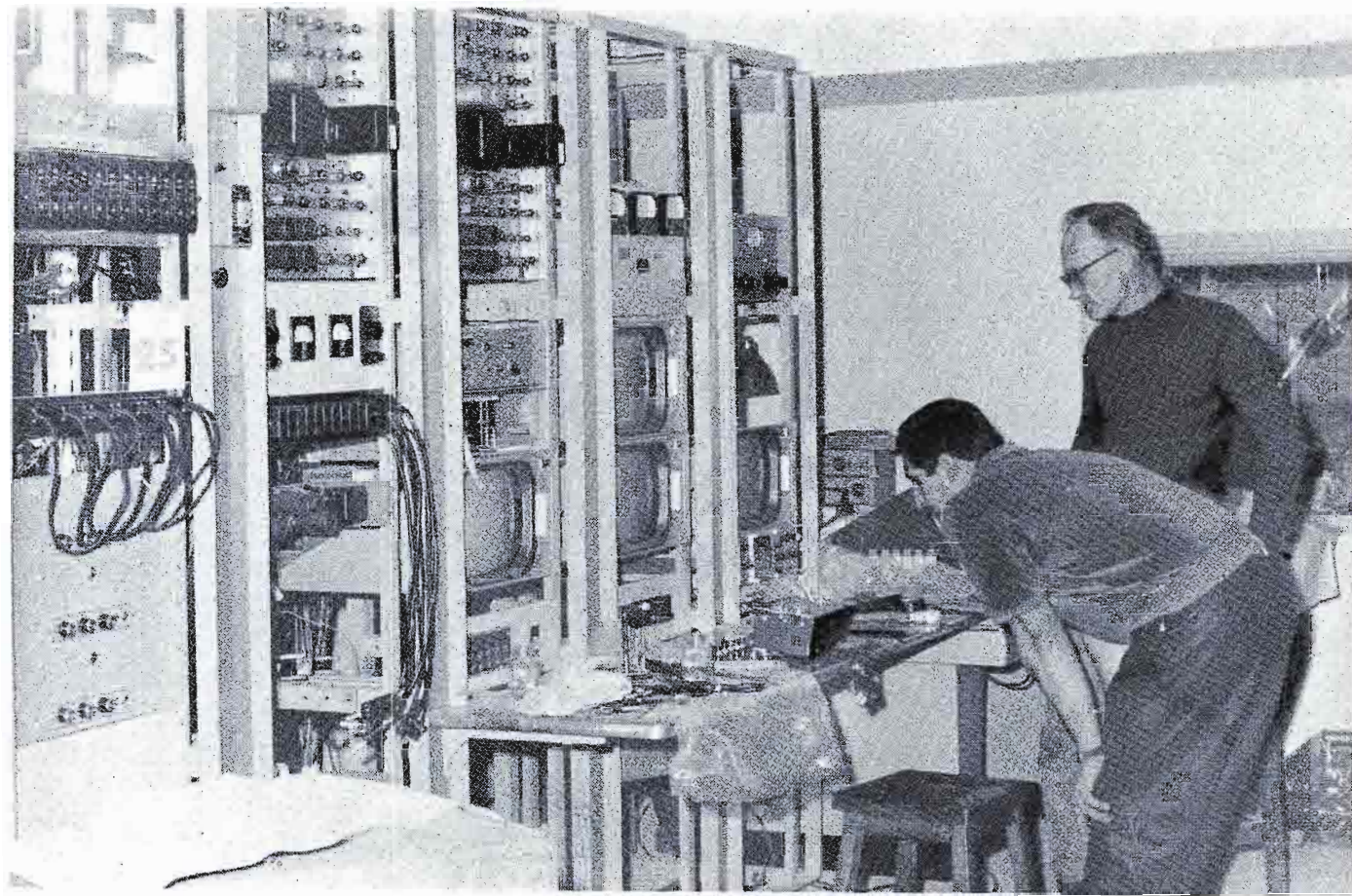

FIG. 6 Installation of film chain.

FIG. 7 Installation of terminal and control equipment.



dynamite, as Tierra Del Fuego is solid rock, just a few inches below the surface topsoil.

RCA Victor Argentina technician Orlando Villareal arrived in Ushuaia on July 20, 1967, to begin the installation of the equipment, which proceeded so well that the Ushuaia station was in operation on a simple closed circuit system on the 24th of July and was broadcasting programs on August 3. A note of interest here is that for this station the field strength and transmission tests were performed with the aid of a tugboat, graciously loaned to the station by the Argentine Navy. The vessel, A.R.A. Ghiriguano cruised along Beagle Channel and the signal transmitted from the RCA TTL-500AH transmitter was clearly received on a standard home receiver via a simple yagi antenna, over a path of 70km.

Each station is managed by a Director and a Chief Engineer. In Ushuaia the Director is Mr. Ego Pereda and the Chief Engineer is Mr. Angel Bizzani. In Rio Grande the Director is Mr. Godofredo Videla and Mr. Rodolfo Rivarola is the Chief Engineer. Both directors are completely identified with the social and economic conditions of Tierra Del Fuego. They are secondary school professors with extensive experience in education and the educational needs of their country.

The Equipment

The live studio and the maintenance and warehouse area are located in the two-story wing of the building. The studio is some 430 square feet in area and uses an RCA type PK-330 transistorized vidicon camera for telecasting locally produced discussion shows and news reports, which amounts to approximately 15 percent of the daily programming.

In the control and program area are the monochrome film chain, equipped with RCA type PK-302 vidicon film camera, type 614EVMS 16mm film projector, type 332 dual drum slide projector, and type TP-11 multiplexer. The control console was fabricated in Tierra Del Fuego and includes an RCA BC-5 consolette and TS-2B switcher for control of the turntable and audio tape input sources. Video control is provided by RCA TS-2BS and TS-5A equipment with PX-14C monitors. There are six video inputs and two outputs. Next to video control is the announce booth where the two announcers provide daily news and advertising messages.

The RCA TTL-500AH VHF transmitter has been installed in the rear of the control and studio area with its 11kw notch-duplexer. Transmission line is a 300-ft. length of 1 $\frac{5}{8}$ " Helix feeding an omnidirectional ring-type antenna.

Thus far, in the 19 months the equipment has been on the air, operations have proceeded smoothly without any interruptions in programming due to equipment malfunction.

Programming

The major sources of programs are the commercial television stations in Buenos Aires. Films of news and current events, educational programs, and other feature material are obtained from those stations and from different foreign embassies in Argentina. Some U. S. serials are also shown, as well as similar programs from other countries. Both stations have plans to purchase television tape machines as soon as possible in order to develop a library of prepared programming and consequently increase their daily broadcast schedule. At the present time they are on the air from three to five hours a day, usually in the evening between five and ten p.m. For the locally produced shows, all sets, props, and art production materials are manufactured in the building by station personnel.

A Successful Project

Official inauguration of the stations took place during ceremonies conducted on the 23rd and 24th of October, 1967. The affair at Tierra Del Fuego was honored by the presence of Dr. Guillermo Borda from the Ministry of Internal Affairs and Captain Carlos Ibarra, Head of the National Council of Radio and Television for Argentina. The Governor of Tierra Del Fuego, Rear Admiral Jose M. Guzman, spoke eloquently, summarizing the hopes the Governorship had for television in their country, the appreciation of the electronic technicians of the island, who for the first time could study broadcast television equipment in operation, and the heartfelt thanks of the people of Tierra Del Fuego, for the implementation of this vital service that links them with the rest of the world.

Mr. O. Casagrande, RCA Victor Argentina's delegate to the inauguration, accepted the recognition of Governor Guzman, Economy Secretary Mateo Garcia, and other officials, for the role RCA played in establishing the television service.



FIG. 8 Terminal and control area looking thru to announce booth.

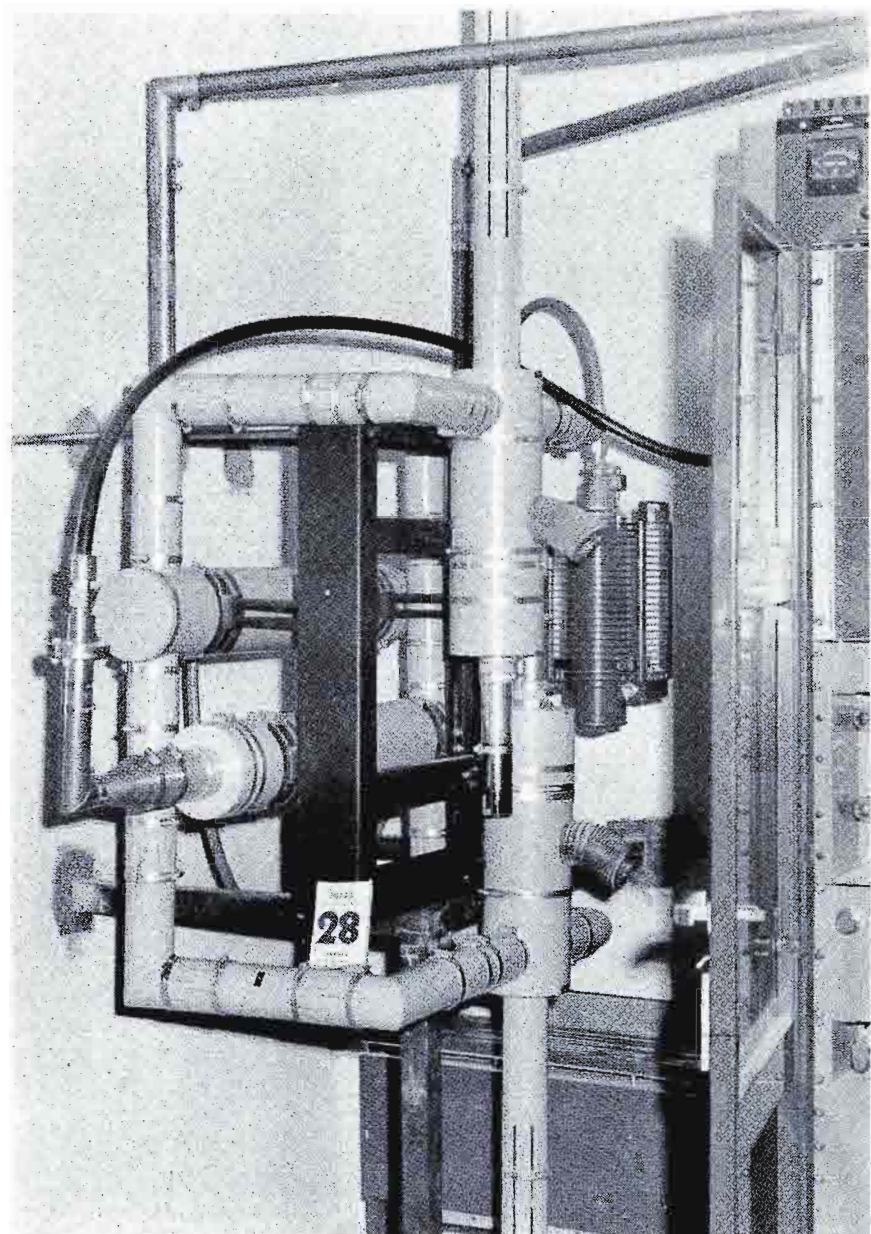

FIG. 9 11KW Notch Diplexer adjoins TTL-500AH TV Transmitter.

NEW TR-60 . . . COMPLETE TV TAPE PRODUCTION CENTER

New Performance Features
For Color and Monochrome...
High Band and Low Band

We've been asked if the TR-60 is a "souped up" TR-50 or a miniaturized TR-70. Actually, it is neither. But the TR-60 does borrow good features from both machines. It has the unmatched compactness of the TR-50 (same size) but has much more of the production instrumentation of the TR-70. It has all the solid state circuitry of the 50, but differential phase and gain are considerably better than the 50, and s/n equals that of the 70. In fact, frequency response, K factor, moire, linearity and other parameters reflecting color performance closely approach those of the quintessential TR-70 color tape recorder. The TR-60 is available as either an NTSC or PAL machine. In the latter case the TR-60 features switchable NTSC/PAL operation.



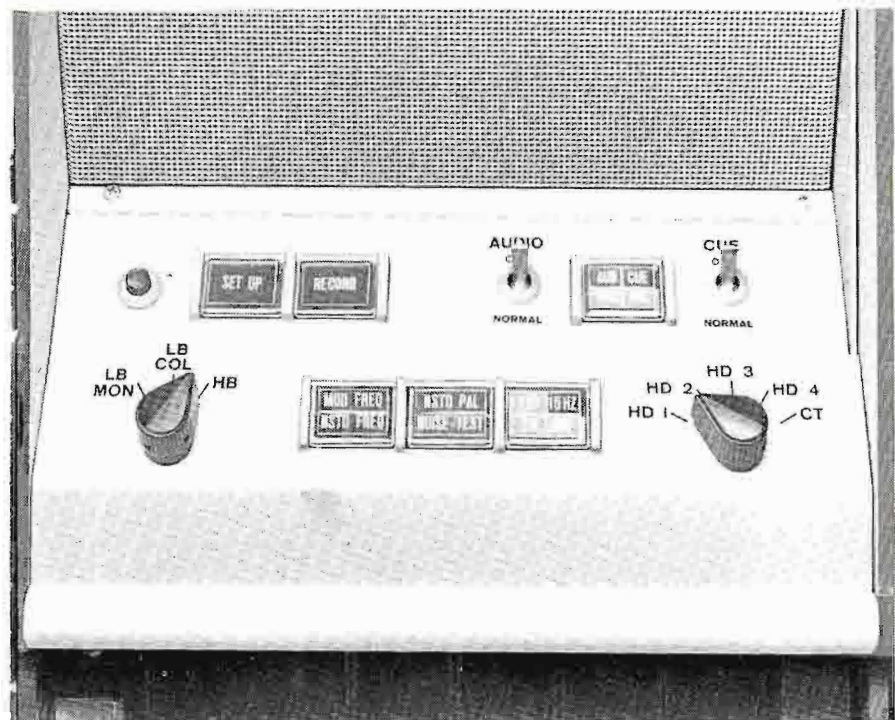

FIG. 1 Record panel contains controls for set-up and record, audio and cue, switching between mono, lowband and highband color, selecting cue track or heads for reading level and currents, and status lights for important functions.

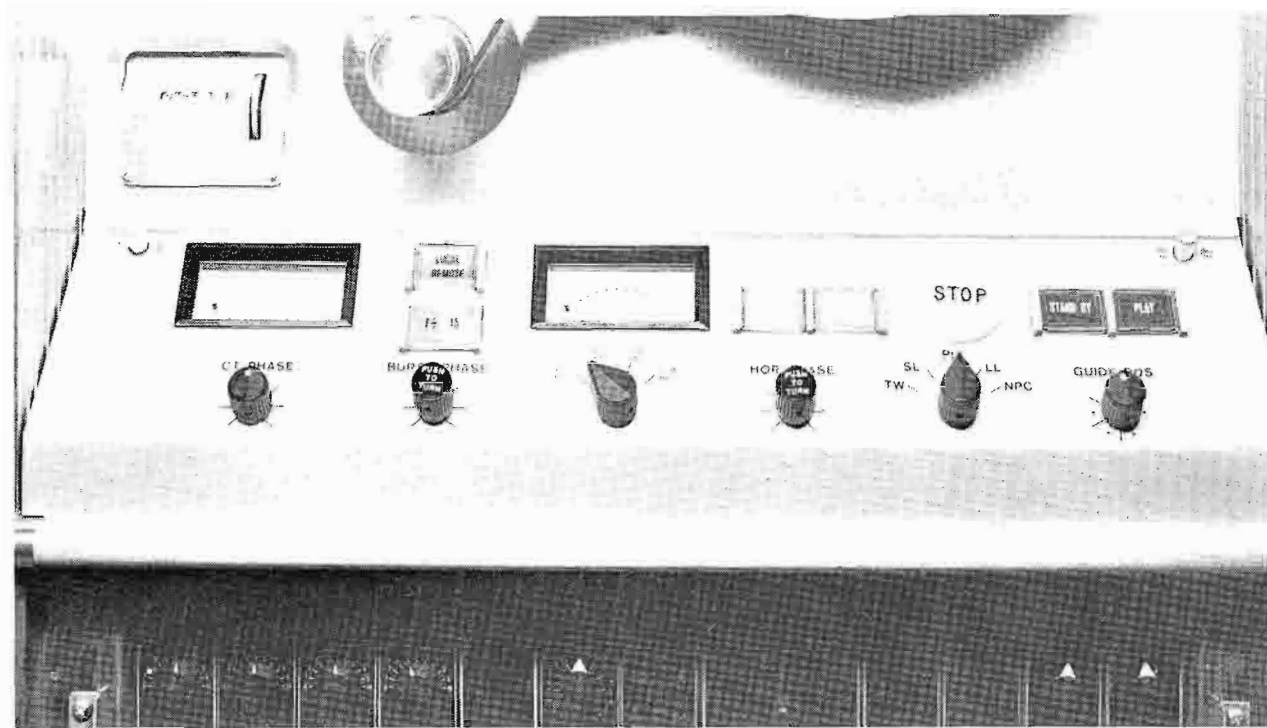

FIG. 2 Playback panel contains controls for control track, burst and horizontal phase, local/remote and 7.5/15 ips speed, machine operating mode, guide positioning, forward and reverse, play, standby and stop. A multimeter switch permits reading record and playback audio levels.

Big-Machine Production Facilities

The TR-60 has everything necessary to make it a complete tape production center. Not only is it designed to accept all the accessories available to the TR-70, but its technical performance, which is capable of 3rd and 4th generation dubs, is ideal for applications such as delaying networks, recording and dubbing commercials, or "mastering" for post-production type work.

Simply fit the prewired Electronic Splicer to it and you eliminate the need for physically cutting the tape for production effects. Then add to this the Tape Editing Programmer, which allows you to preselect splice points and then edit automatically. A further time saver would be the Rapid Record Optimizer by which you can set individual record head currents in seconds instead of minutes. Then, for the ultimate in color picture quality, you may add the CAVEC (chroma amplitude and velocity error corrector) which corrects color subcarrier phase and amplitude on a line by line basis. Finally, the Color Dropout Compensator, which when dubbing, reinserts small losses of color in defective tapes, making the dropouts invisible.

Built into the TR-60 are a guide servo which automatically positions the vacuum guide to eliminate skewing, provision for accurately setting the position of the vertical interval, a tape motion sensor and a cue channel. A rear-side erase head erases from the base side of the tape, avoiding contact with the oxide and eliminating any possibility of scratching.

Head Resonance Compensation

A high input-impedance preamplifier contributes to the excellent signal-to-noise ratio and differential gain of the TR-60. To compensate for the resonance effects that would otherwise be introduced by the heads that are feeding this high impedance circuit, two anti-resonance (resistance and reactance) controls are provided. These two controls permit the operator to match the response of the heads individually and very accurately to eliminate the differential banding. The adjustments are very easily made using the test tape supplied with the TR-60.

Complete Sync Regeneration

One very important big-machine feature of the TR-60 is sync regeneration. Sync coming off the tape being played may be noisy or it may have small disturbances on it affecting the picture quality. The processor in the TR-60, however, completely regenerates both the horizontal and vertical sync, thus providing a perfect input signal for another tape machine, terminal equipment or transmitter.

New ATC Circuits

Picture quality is dependent upon the ability of the automatic timing correction circuits to correct for the jitter of the servo, which can be as high as 120 nanoseconds in any machine, and for the possible quadrature displacement of the four heads.

The TR-60 uses front porch switching, enabling

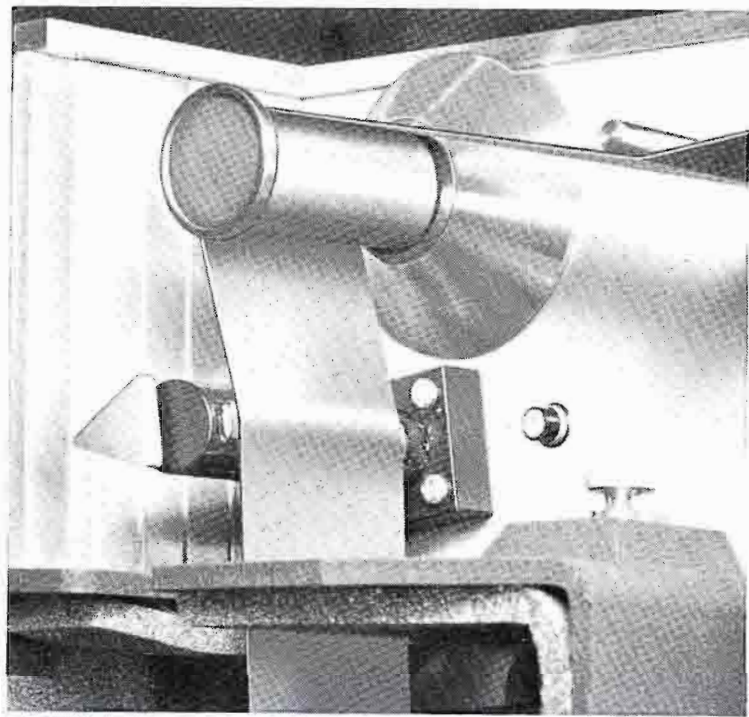
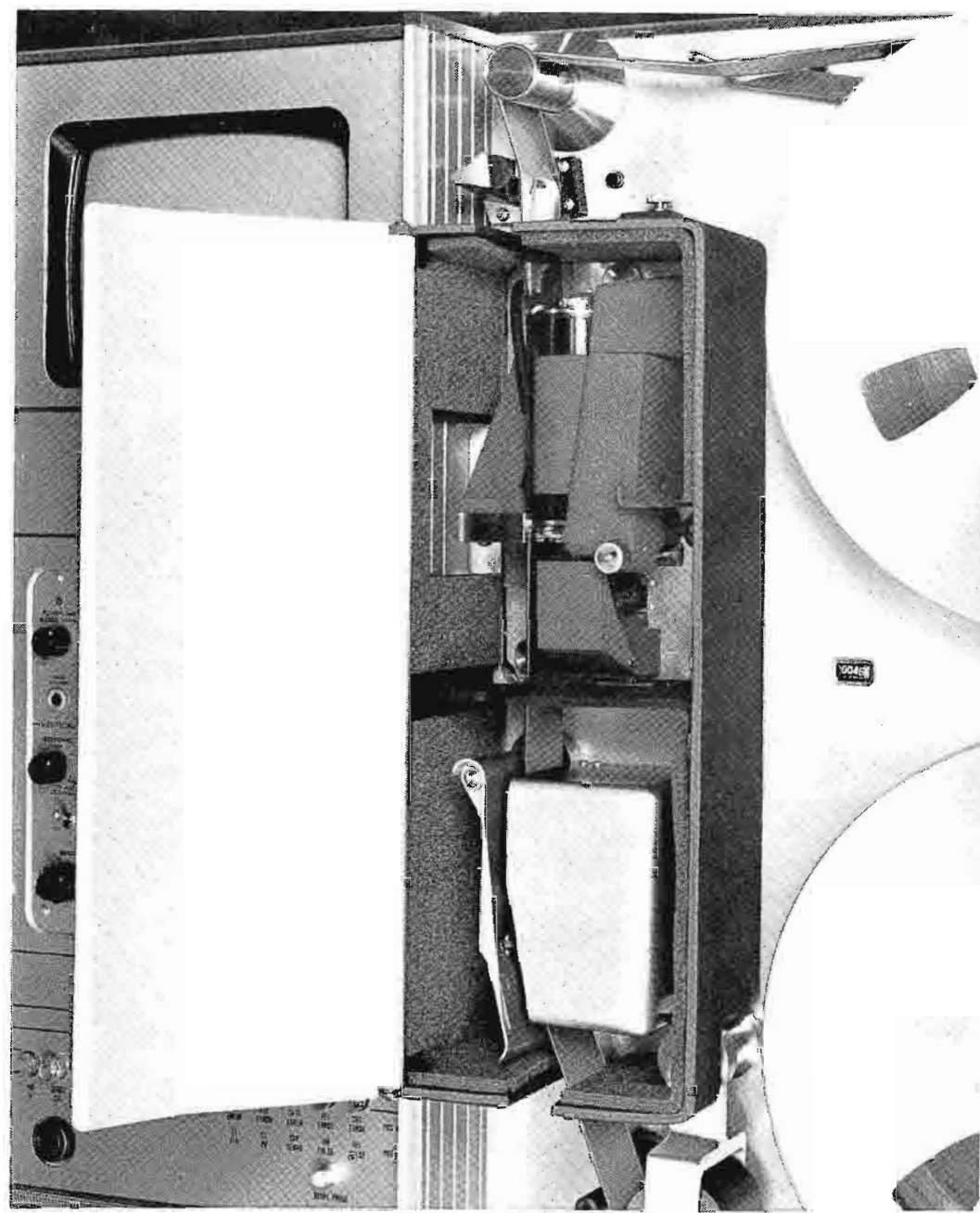

FIG. 3 Rear side erase head erases recorded material through the base side of the tape, not the oxide side, thereby minimizing tape scratching and damage.

FIG. 4 Vertical tape transport offers virtually straight tape path for quick and simple threading, employs high performance universal head-wheel that operates on both high- and lowband standards.



the ATC to sample the leading edge of sync as well as correct the leading edge of sync. Some machines sample the trailing edge while correcting the leading edge, which is a less accurate method of correction.

The color ATC of the TR-60 compares the burst on the back porch with subcarrier from the sync generator. The combined monochrome and color ATC circuits reduce the overall timing error to less than 3 or 4 nanoseconds, a value which produces excellent color pictures.

Error-Proof Controls, Indicators

The operator-oriented, sloping control panels of the TR-60 follow in the footsteps of the big machines. Record and playback controls are grouped and separated to eliminate possibility of human error. Generous use of meters and status lights permits the operator to duplicate quality in tape after tape.

Controls permit, among other things, choice of

deviation standards, servo replay mode, machine mode, and control of burst and horizontal phase via push-to-turn controls. Indications are provided for audio and cue track levels and individual head record currents.

The control panel is identical for domestic and international models of the TR-60 machine. The domestic model is, of course, for use on NTSC color standards, high band or low band. The international model is for use on NTSC or PAL, and a flip of a switch changes the machine over from one standard to the other. Both machines may be remotely controlled.

Deluxe Monitoring Facilities

The best picture and waveform monitoring facilities are offered, including pulse cross display on the picture monitor, and display of all critical machine waveforms on the specially modified Tektronix 529

FIG. 5 Eye level monitoring facilities include a picture monitor, waveform monitor and switching panel. The picture monitor incorporates the pulse cross display, to help the operator to discern timing errors, displaced equalizing pulses, sync width and other defects. A channel identification signal eliminates need for manually placing marks on the screen.

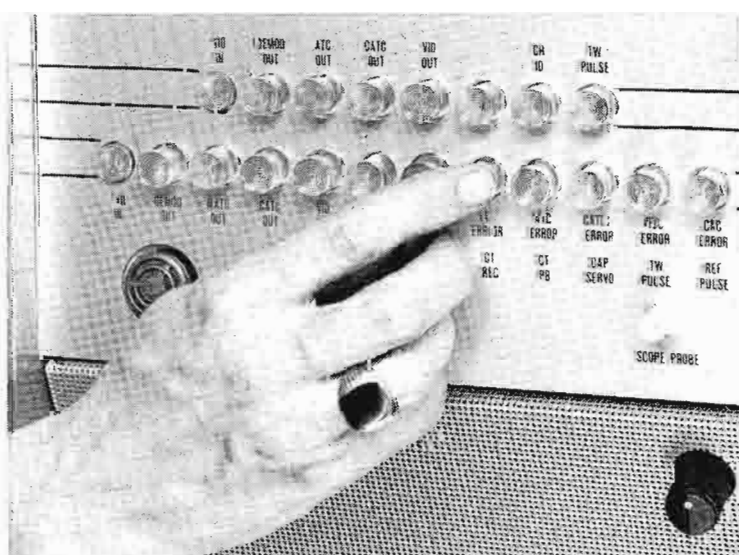
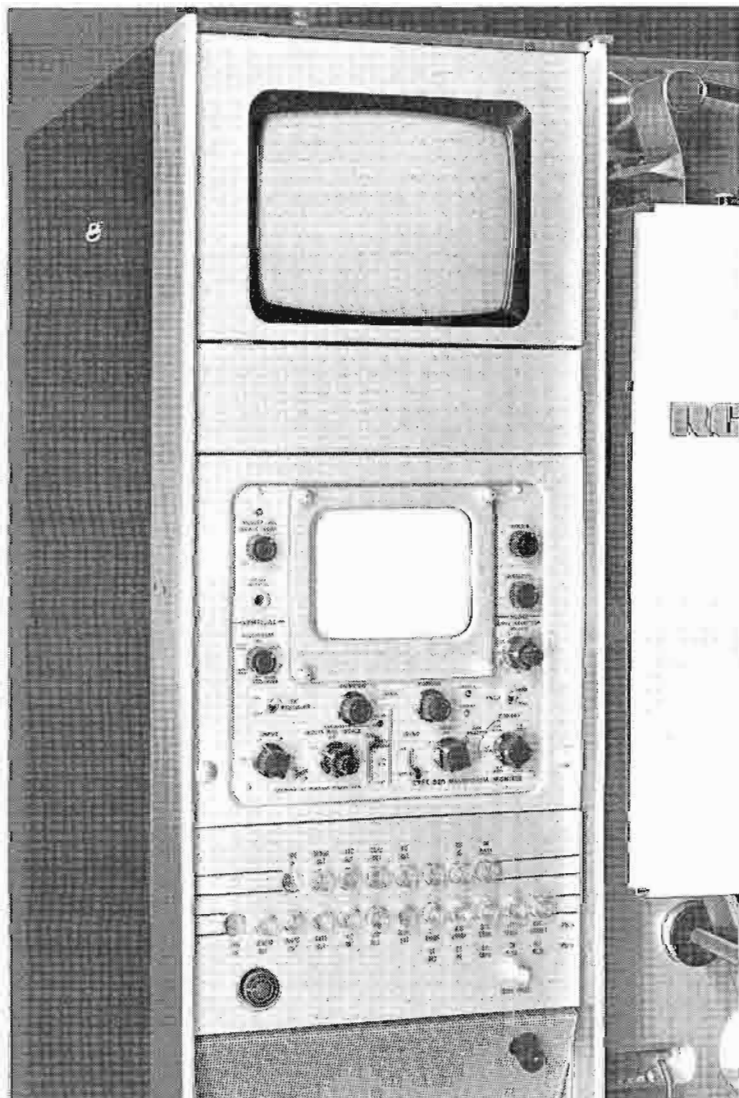

FIG. 6 Switching panel makes available more than 50 discrete signals covering video, audio, waveform and DC voltage information on a pushbutton basis.

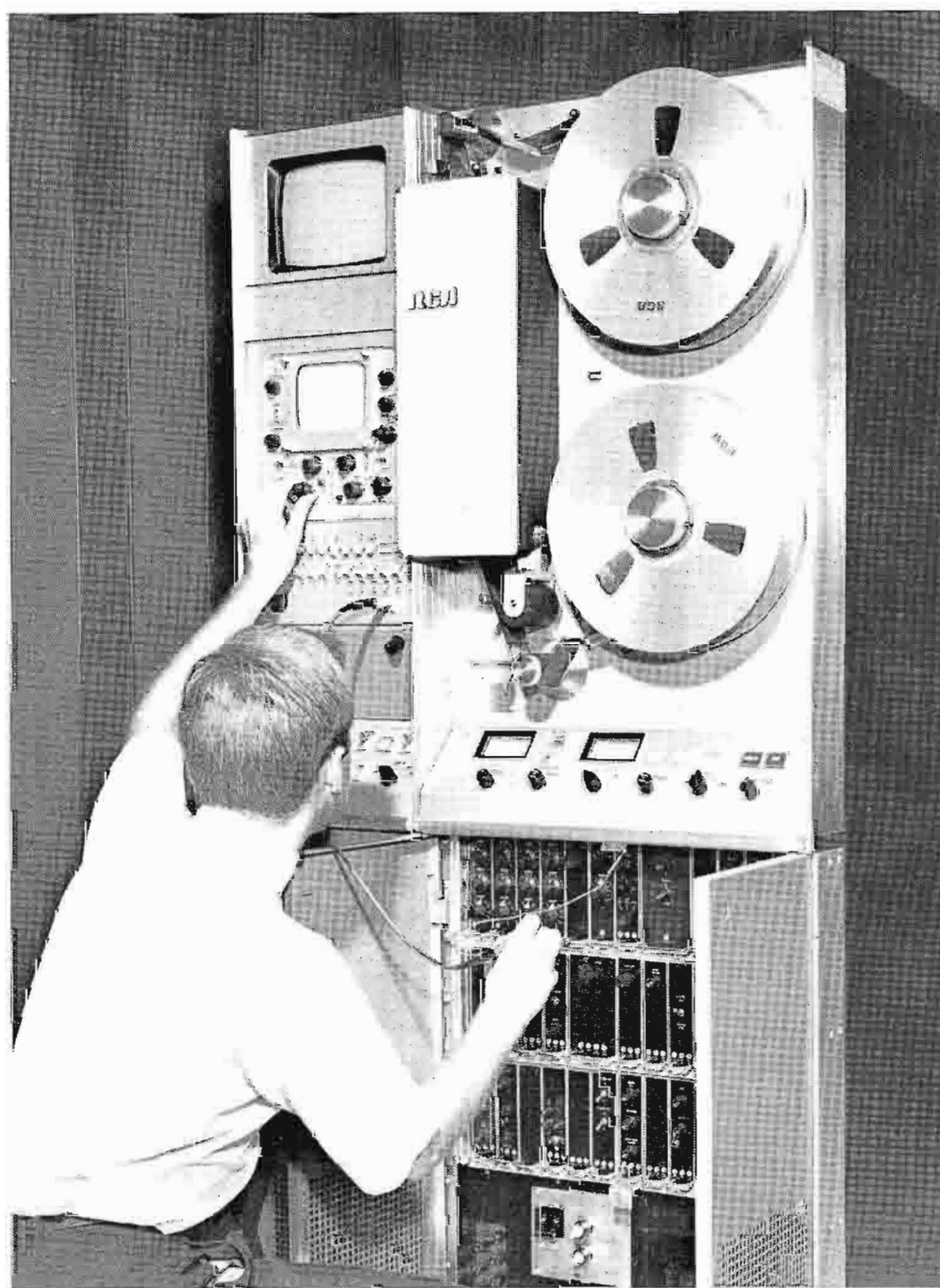

FIG. 7 An "external probe" input to waveform monitor permits scanning a multitude of test points for troubleshooting using the TR-60's built-in oscilloscope.

waveform monitor. A second input permits checking of waveforms at all module test points through use of an external probe.

20T Pulse Evaluation

Color performance of the TR-60 is evaluated by the same method used in evaluating TR-70 color performance. Known as the 20T pulse test, it adds an accurate color dimension to the widely accepted 2T test for monochrome. Combined, the two provide the ultimate means for evaluating color picture performance.

Conclusions

The TR-60 high band color tape recorder was designed to fill the need for a compact machine with enough facilities to make it an independent production entity, and incorporating the latest state-of-the-art circuitry for the best color pictures seen in a machine of its size.

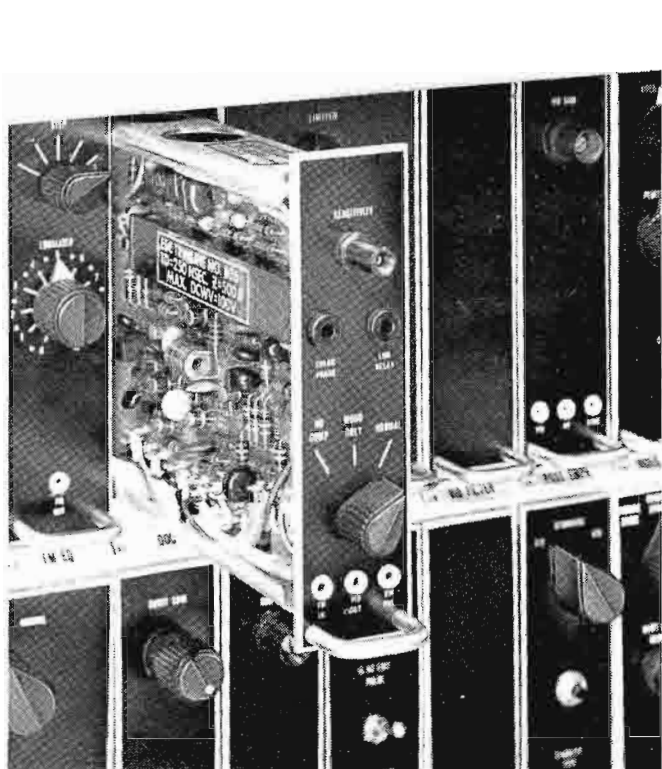

FIG. 8 Dropout compensator module features NTSC corrected color phase insertion and all electronic setup. The TR-60 is prewired for insertion of this plug-in module.

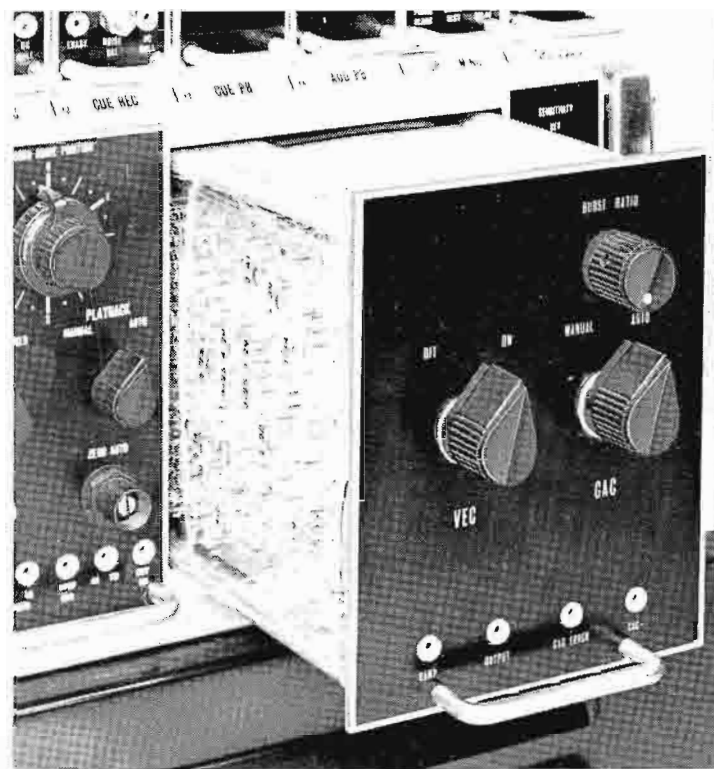

FIG. 9 CAVEC module performs chroma amplitude and velocity error correction on a line-by-line basis, helping operators achieve quality replays, free from banding. The TR-60 is partially prewired for this accessory.

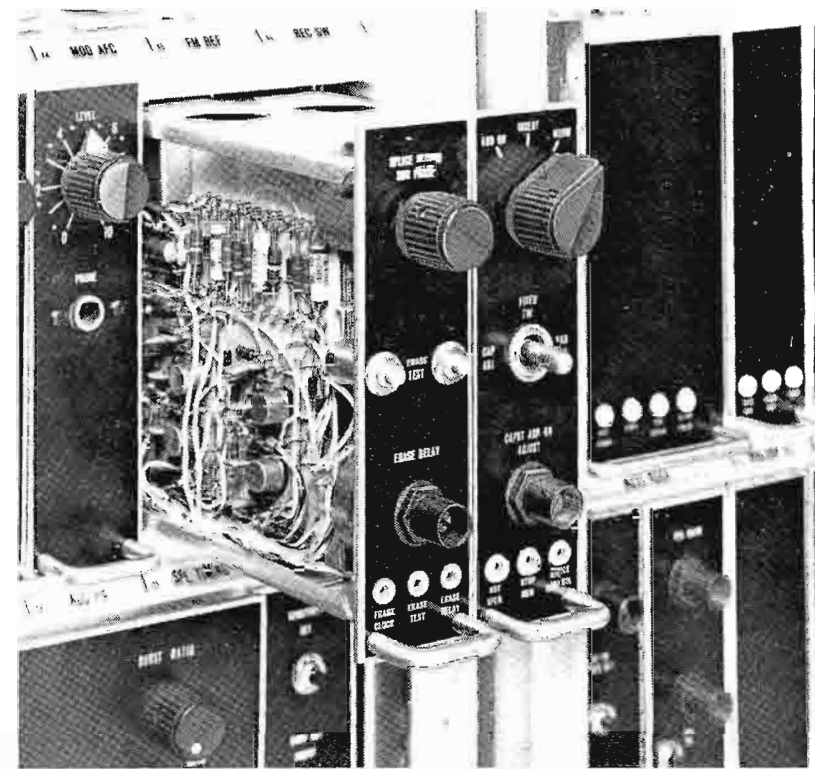

FIG. 10 Electronic splicer allows changes, add-ons, inserts to recorded material without cutting tape. TR-60 is prewired for these plug-in modules. This accessory is required for use of the tape editing programmer.

Major TR-60 Specifications High Band Operation

| | 525 Line Standard | 625 Line Standard |
|---|--|--|
| Bandwidth | ± 0.75 dB 60 Hz - 4.1 MHz -3 dB max. at 4.5 MHz | ± 0.75 dB 50 Hz - 5.5 MHz -3 dB max. at 6.0 MHz |
| Rise and Decay Time | 110 NSecs. | 80 NSecs. |
| Signal-to-Noise | 46 dB | 43 dB |
| Transient Rating (2T/20T) (525 - .25 μ sec. HAD 2T) (625 - .20 μ sec. HAD 2T) | 1.5%/1.5% | 1.5%/1.5% |
| Amplitude Linearity (Blanking-to-White) | 2% | 2% |
| LF Tilt | 1% | 1% |
| Differential Gain (Blanking-to-White) | 5% | 5% |
| Differential Phase (Blanking-to-White) | 5° | 5° |
| Moire | 40 dB | 32 dB |

Performance figures are for 15 IPS operation.

NEW TA-19 VIDEO PROCESSING AMPLIFIER



FIG. 1 Basic TA-19 Video Processing Amplifier, less AGC and Burst Regeneration.

With Burst Regeneration
and Color AGC

Back in the dear, dim days of the late 40's, the Broadcast industry gave up trying to produce perfect television signals and decided that everything that went wrong could be fixed up in a single device known as the Video Stabilizing Amplifier. RCA's derby entry was the TA-5; and for monochrome signals, it came close to becoming a complete success. Sync was clipped and reshaped; the blanking base line was clipped and clamped; and if black level was a little high or low, no harm was done. The video and sync signals could be separated for genlocking and feeding non-composite switchers, which were the vogue in those days. There wasn't much else you could do or even wanted to. For that day and age, the stabilizing amplifier was practically the complete correction device.

Then color reared its beautiful head. Subsequent RCA designs such as the TA-7A and the TA-9 kept pace with the state of the art by offering such sophisticated techniques as white stretch, white clip and blanking reinsertion (synchronous signals only). An attempt at frequency response correction was also made in these designs, since separate chroma control was included to correct for high or low response at the color subcarrier frequency. These particular devices had no sooner proven their worth when video

tape, first in monochrome and then in color, called for a super-sophisticated device. As the state of the art developed, the demands for more stabilizing amplifier functions increased. One might suspect that these devices had a tendency to spoil the Broadcast industry. Since the stab amp had always been a catch-all to clean up as much as possible of the composite video signal, every new defect that appeared had to be fixed in the stab amp. Broadcasters have even insisted that the device remove noise from the video signal without degrading it in any way! *There are some ideas on this.*

The main problem in designing a stab amp was trying to decide which functions would serve the Broadcaster best and which could be left out (for economic reasons) without sacrificing the utility value of the device. The RCA approach was to determine everything that could go wrong with the video signal in the process of origination and transmission throughout the broadcast day. The list concocted was most impressive because of its length. When all of the decisions had been made, the device could no longer be called a video stabilizing amplifier. Its functions were so diverse that the name was changed to Video Processing Amplifier.

The following narrative describes the ills which can befall a video signal and how the TA-19 Video Processing Amplifier corrects these defects so that the signal is usable for broadcasting.

Automatic Signal Source

One feature of the TA-19 is its ability to regenerate sync and set-up, and to automatically produce these signals at the output the moment the input signal is lost.

Assume that the STL fades. Obviously, things would be happening to the transmitter, but for the TA-19. If, for example, complete composite signal is lost at the input to the TA-19, the unit automatically switches to self generation of sync and set-up. Even with complete loss of STL, this output could be used at the transmitter to maintain modulation. Or, it could be used as a source of "after hours" modulation when the studio is shut down. When the signal is restored, the TA-19 automatically returns to it. The local oscillator is stable enough to maintain very tight sync of monitors and receivers.

Effective Hum and Glitch Suppression

The TA-19 employs differential inputs, a fast driven sync-tip clamp and a driven back porch feedback

clamp to suppress rectifier glitches, hum and switching transients which may appear on the system ground or on the unbalanced input. An example of hum added to the video signal is illustrated in Fig. 2. As you can see, the amount of hum exceeds the video amplitude, yet the output is completely free of hum. This is achieved by the two driven-clamp circuits, one of which is fast, and the other slow operating.

The differential inputs suppress glitches, transients and hum appearing on the common mode or ground of the system, such as the difference in potential between power line neutrals at separate locations. This hum appears on the neutral and consequently on the video. It is especially noticeable when the station is locked to color subcarrier or crystal rather than line. The TA-19 will suppress 10 Volts of hum and transients appearing on the common mode input by a factor of 46 dB.

Adjustable Set-Up, White Clip, White Stretch

Control of set-up (Pedestal) which is actually a small amount of blanking signal added to the video, is available on both the local and remote panels. This control operates in the automatic signal source mode (black signal) as well as in the normal video mode. Set-up is adjustable to ± 30 percent.

FIG. 2 Waveform showing common mode hum on input signal (top) and TA-19 output (bottom).

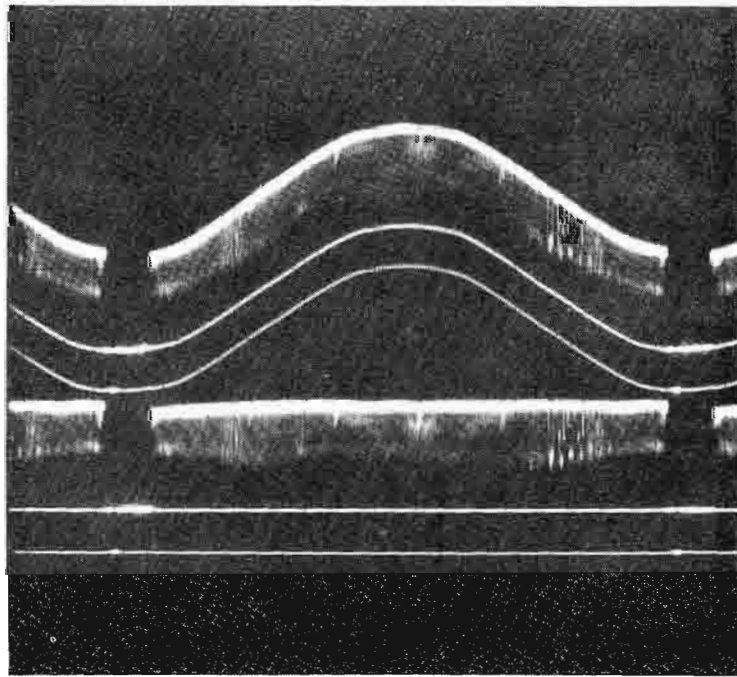

FIG. 3 Waveforms showing how drastic tilt on input signal is cleaned up in the output of the TA-19.

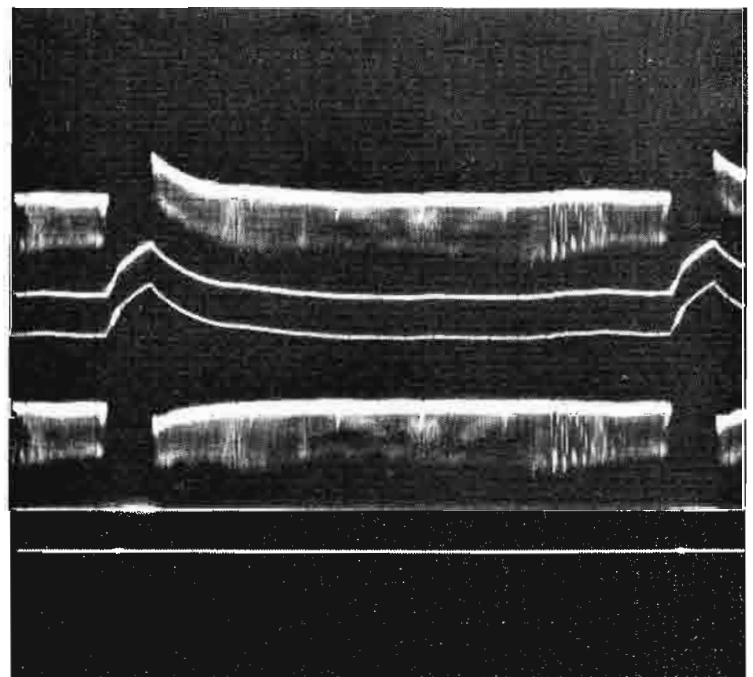

FIG. 4 TA-19 input and output waveforms show noise on vertical display (top) and clean blanking interval (bottom).

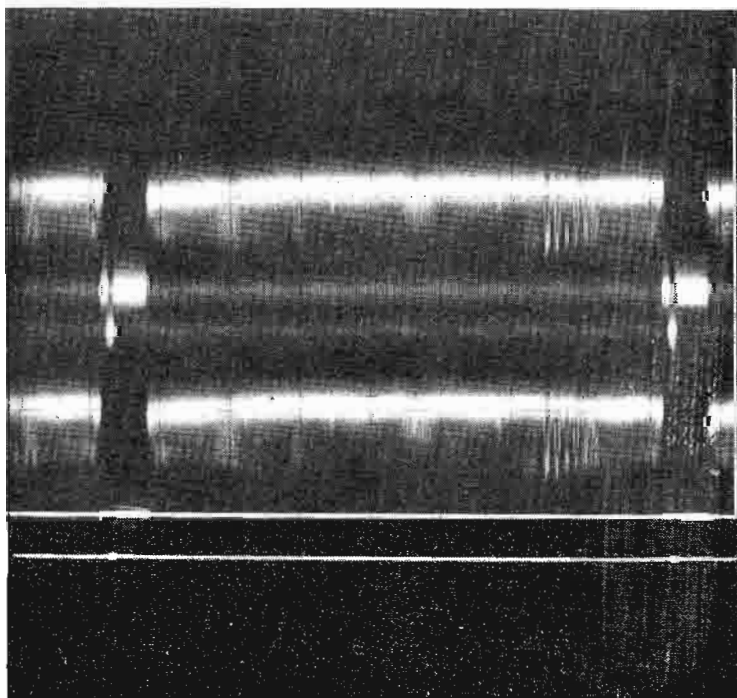
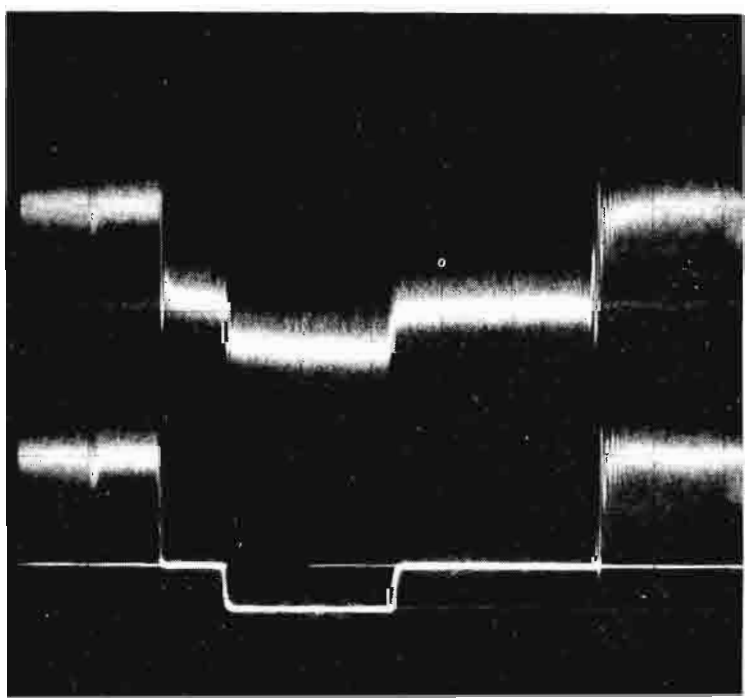

FIG. 5 Horizontal waveform (top) shows noise and negative spikes. In TA-19 output (bottom) horizontal blanking and sync is noise-free.



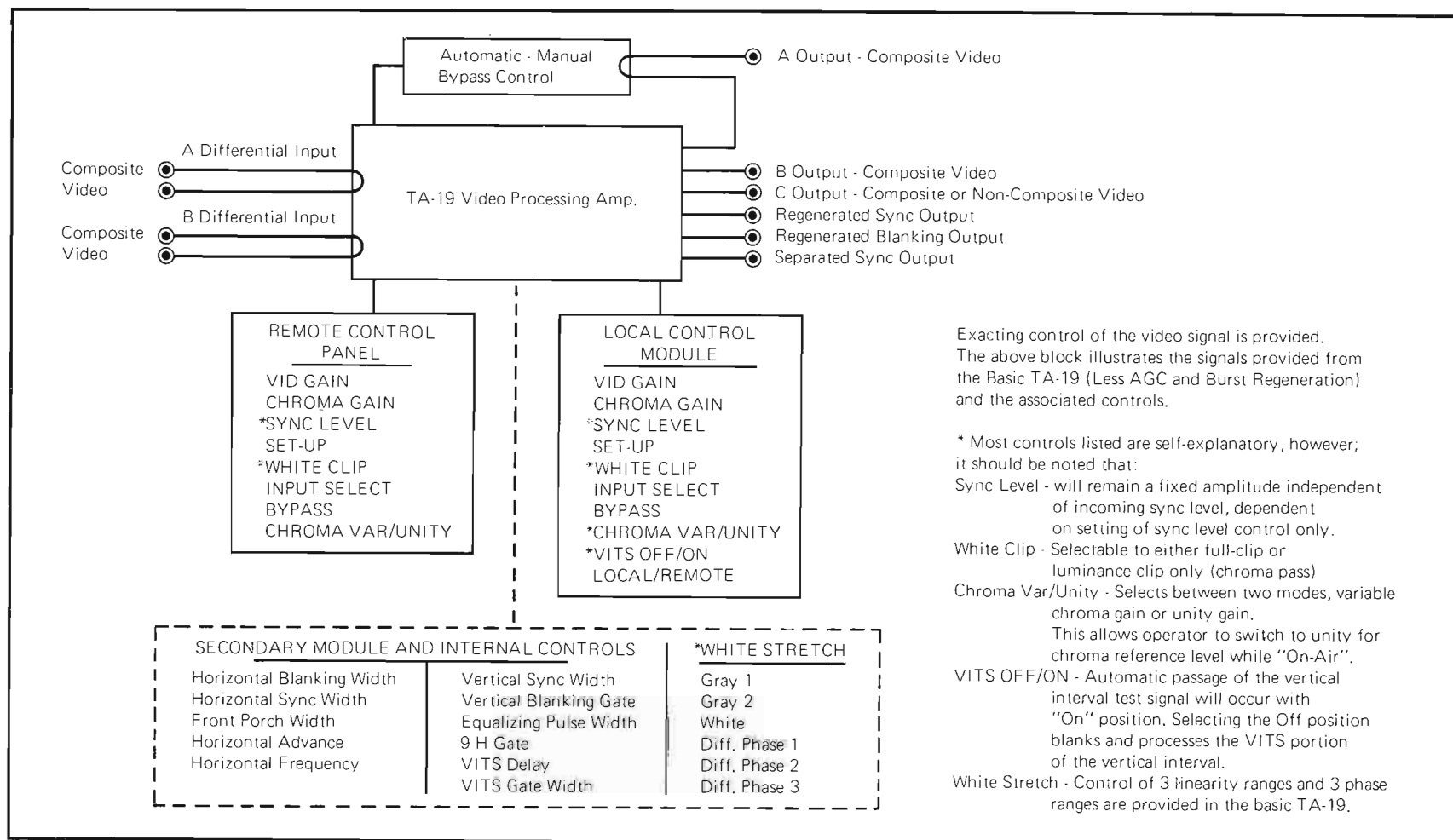

FIG. 6 Block diagram illustrating the signals provided from the basic TA-19 (less AGC and burst regeneration) and associated controls.

There is no need to worry about transmitter over-modulation. Just set the white clipper to the desired clipping point and video will not exceed the prescribed level. The clip will work over the range of 105-125 percent of white level. This is a very sharp clipping action, clipping only the amplitude for which it is set, and not a parabolic or otherwise distorted clip as sometimes found. Selective clipping modes are provided. By a jumper change, clipping acts on luminance only and chrominance passes unclipped.

The TA-19 contains white stretch circuits to compensate for the white compression in transmitters. Basically a non linear amplifier, the white stretch amplifier provides 6 dB of white boost in three steps from gray to white. Differential phase is also adjustable in three steps.

Complete Sync and Blanking Regeneration

Faults in the sync and blanking areas are the cause of worry to many video engineers. Most broadcasters are familiar with the case of the microwave signal fadeout, where the signal gets extremely noisy and finally the monitors and receivers start to unlock and roll. Normally, it is then necessary to switch back and forth from black to net periodically to determine if the signal is good enough to lock receivers. In this case the TA-19 will generate normal amplitude sync and blanking with a composite input signal of only .25 Volt. It is designed to correct for sync and blanking faults in amplitude, width and timing. It will even compensate for missing pulses. The TA-19 adds a completely new sync and blanking interval. The "used" input pulses merely serve as a timing reference. Therefore, all it needs is something that re-

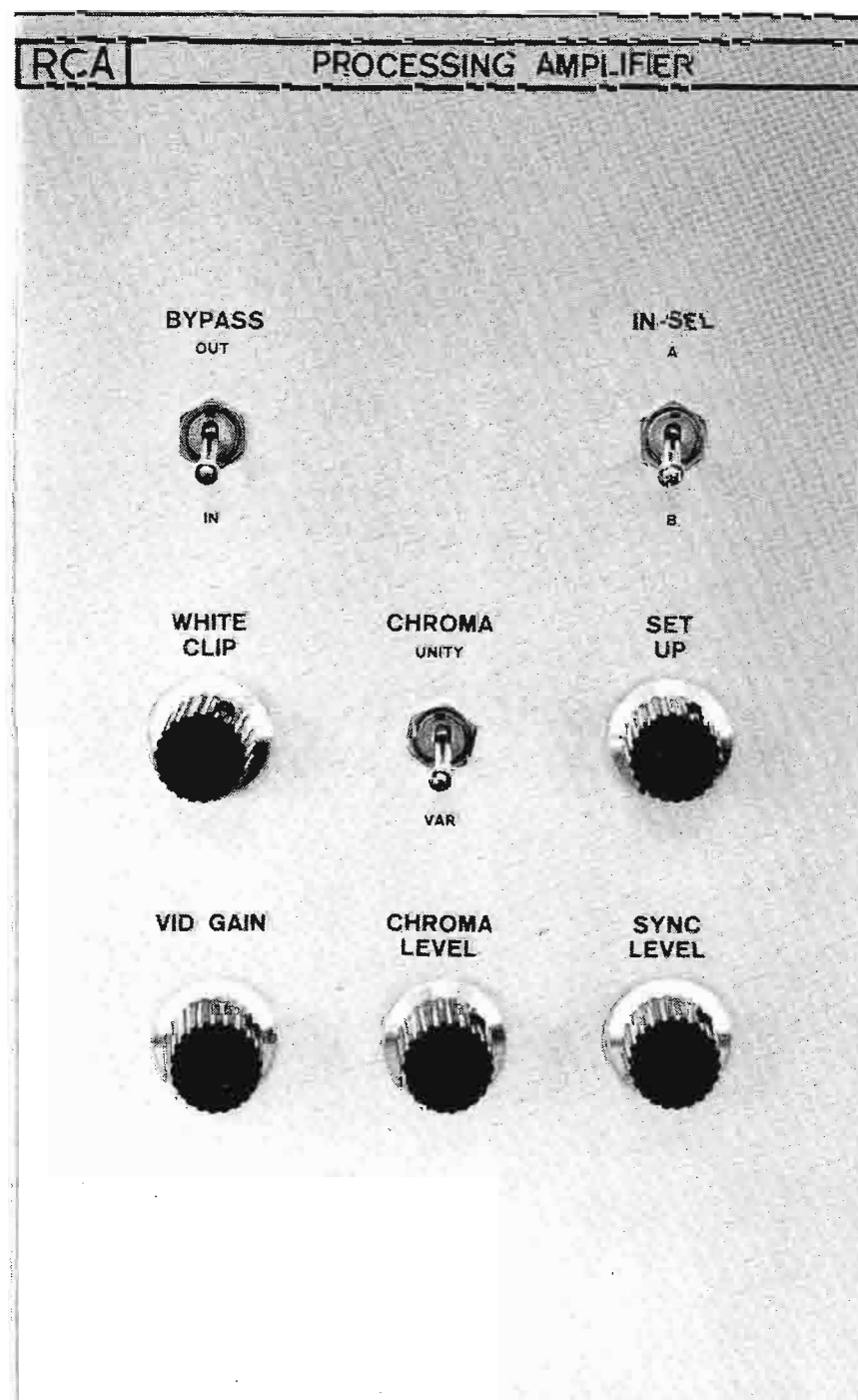

FIG. 7 Remote control panel for TA-19.

sembles a pulse at the input, and out comes clean sync and blanking pulses capable of locking receivers with extremely poor signals at the TA-19 input.

Sync, blanking and drive signals are supplied to cameras and TV tape independently. These pulses may be generated by a common sync generator or by separate sync generators. In either case, the pulse widths and delays might be different. Since the TA-19 generates a completely new sync and blanking signal, the proper widths may be adjusted at the TA-19 and will be maintained. The predominant controls are located on the front of the modules for adjustment of blanking width, sync width, front porch width and horizontal advance. Additional internal module controls are provided as indicated on the block diagram of Fig. 6. Individual path delays and variable widths are therefore compensated for in the instrument. Amplitude of sync on the composite output will be dependent only on the settings of the manual controls on the front panel. Should equalizing or horizontal pulses be missing from the incoming signal, the TA-19 will "flywheel" and insert the pulses back in the signal.

Automatic Chroma/Monochrome Processing

Sense circuits in the TA-19 operate to completely eliminate unwanted signals while passing either monochrome or color. With a color signal, burst, of course, is passed in the horizontal blanking interval. When burst is not at the input, as with a monochrome signal, the gate closes and the complete horizontal blanking interval is processed.

Three Video and Three Pulse Outputs

Three 75 Ohm video outputs are provided in the TA-19. Two of these, which might be used to feed a program line or for color genlocking, are composite outputs. A third, which might be used to feed a switcher, can be switched composite or non-composite.

The three pulse outputs consist of separated sync, regenerated sync and regenerated blanking. Each is available as 4 Volts at 75 Ohms. The separated sync pulse may be used to reference input sync timing. If it is to be recombined with video, the simple addition of a TA-32 Sync Adding Distribution Amplifier will serve the purpose, utilizing the non-composite video output. Regenerated sync may be used to drive monochrome genlock, camera or tape. Or, regenerated blanking could be used to drive cameras or tape.

The regenerated pulses are adjustable in width and delay and are locked to the incoming signal. Consequently, any equipment driven by these signals will be locked to the incoming signal and controlled by the TA-19.

High Impedance, Low Capacity Inputs

The TA-19 has two bridging inputs selectable by a relay controlled either locally or remotely. A field effect transistor is employed by the input, providing an input impedance of one megohm (bridging compensated) with extremely low input capacitance, result-

ing in negligible loading of the source. Frequency response is flat to 10 MHz \pm .2 dB.

Automatic "Failsafe" Bypass

Since the TA-19 is normally in the primary signal path, the automatic bypass was built in as a safety feature. Should power be lost to the TA-19, it is not necessary to patch around the unit, transfer of the input signal to the output line is automatic. This automatic switching also takes place under these conditions: (a) if the DC voltage at the TA-19 output stages rises above a prescribed value; (b) if the power supply fails; or (c) if a critical module is removed from the TA-19.

During bypass conditions, only one of the two inputs is bypassed to the output. The second input, which is used for a test signal, remote feed (or any composite signal), is not bypassed. Bypass can also be switched manually from the control panel.

All-Function Remote Control

The remote control panel supplied with the TA-19 is a standard C size (4 $\frac{1}{4}$ " x 7") to fit New Look consoles. Connections to the unit are by a single cable carrying only low DC voltage, no AC or video. Remote controls are: sync gain, video gain, chroma gain, set-up, white clip, A and B input switching, manual bypass, and unity-variable chroma. Video gain will control video for 1.5 Volt composite signal when working with an input signal of only .25 Volt. Chroma gain allows independent control of the chroma signal to \pm 3 dB of unity (flat response). A switch is provided to switch to unity chroma for a reference (flat frequency response) to indicate the amplitude of input chroma without boost.

VITS Deletion

At times it may be desirable to prevent the network vertical interval test signal from passing, especially when adding a local signal for remote keying or any other purpose. For this reason, a switch is provided on the local control panel of the TA-19 that enables cancellation of the incoming vertical interval test signal. The gate is variable in width and delay to provide single line or several lines of deletion.

Minimum Path Delay

One might expect that an instrument capable of achieving all these functions would have inherently high delay. However, this is not the case. The path delay is only 25 ns, which is the equivalent of approximately 16 feet of video cable. This simplifies the installation of TA-19's in systems which require accurate timing.

Video AGC

The Video AGC module is an optional item. A unique dual detection method and two step AGC action provides extremely precise automatic video level control. Luminance and chrominance informa-

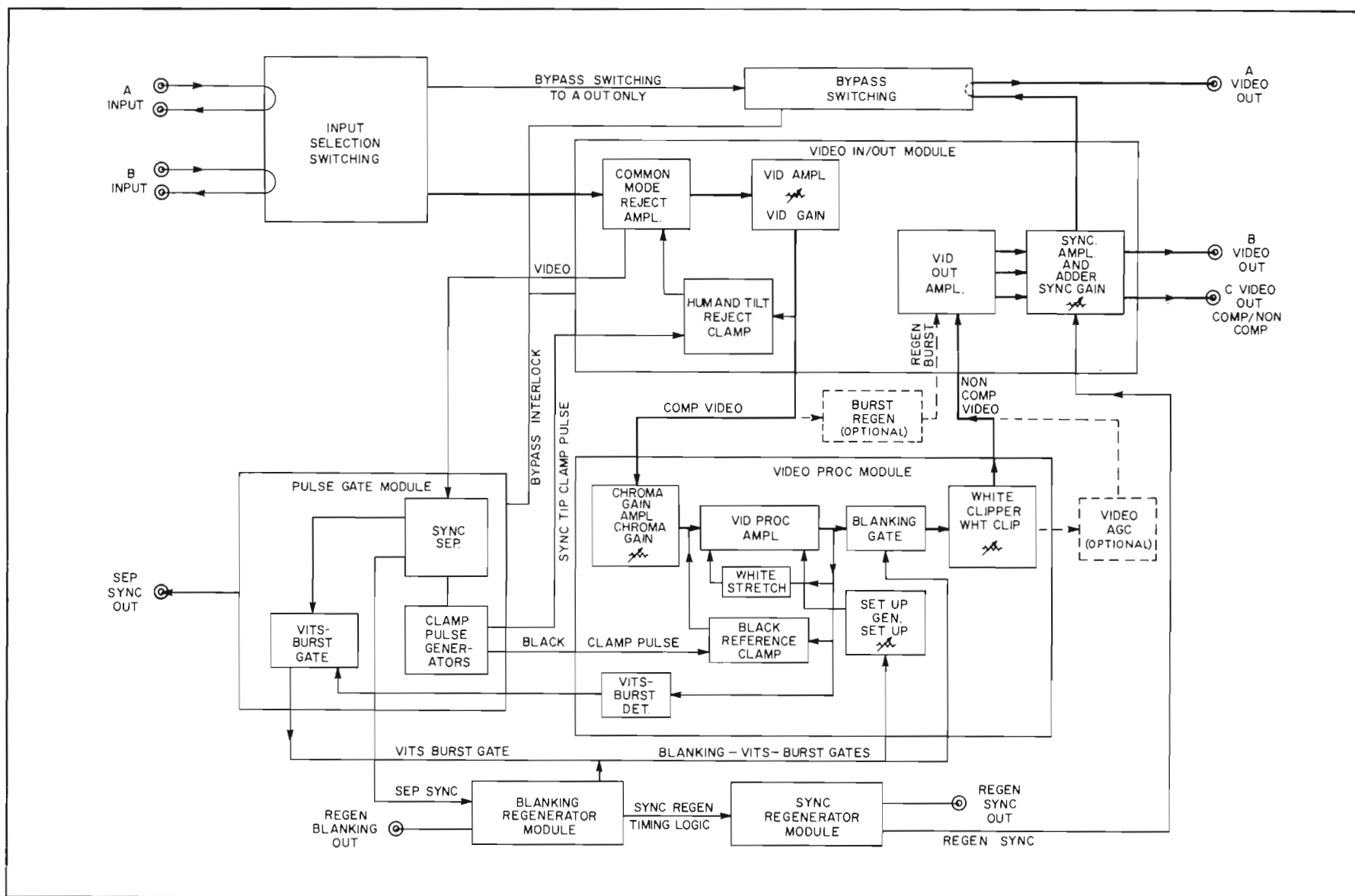

FIG. 8 Block diagram of TA-19 circuits.

tion is not separated and Color saturation and Hue are undisturbed over the complete gain range. Adverse overshoots due to lag (common in AGC recovery systems), is eliminated in this new AGC system. The action is very fast giving the impression of a correct output level at all times.

Three switch selectable modes of control are provided in the TA-19 AGC System:

- Mode #1: Provides AGC referenced to the Vertical Interval Test Signal.
- Mode #2. Provides AGC without external reference signals.
- Mode #3. Automatically references the highest amplitude of both VITS and picture signals.

Controls are also provided to manually adjust output level and to eliminate AGC action. A panel lamp indicates loss of AGC action.

The AGC module is mounted in the frame with the basic TA-19 and Burst Regenerator. Burst levels may vary slightly with gain changes in the AGC. If a precise burst amplitude is required for a particular color system it is recommended that the Burst Regenerator accessory be included in the TA-19 system.

The new AGC system overcomes many of the problems encountered with common AGC systems such as: fade-to-black, average picture level, and attack and release time errors, at the same time minimizing errors in signals with absence of white references.

Burst Regenerator

A separate (optional) module allows independent control of burst amplitude, phase, position and width. The Burst Regenerator provides a constant burst output dependent only on the module controls and independent of TA-19 burst input level.

A Burst Mode Select control allows switching to incoming burst while "On-Air" for correct phase, amplitude, position and width comparisons of regenerated burst.

Automatic deletion of regenerated burst output occurs with a monochrome signal at the TA-19 input. A calibrated control is provided as an indicator for burst phase compensation.

The basic TA-19 frame is wired to accept the accessory Burst Regenerator Module which may be added at any time to provide precise independent burst control and instrumentation. This will allow the transmitter or studio engineer to easily check the regenerated signal with respect to the incoming signal, to avoid color errors.

Conclusion

All of the signal problems that faced the TA-19's predecessor, the stab amp, are still present in the sophisticated color systems of today—plus many, many more. Without straining, some 40 discrete functions of the TA-19 have been counted . . . all of which are necessary to efficient, modern color station operation.



FIG. 1 Recently-completed Technical Information Center displays full line of RCA electronic systems for education. Facilities include systems area (left), conference and presentation area (right), and a small television studio (rear).

RCA INFORMATION CENTER DISPLAYS ELECTRONIC AIDS TO EDUCATION

A most complete array of electronic equipment for educational systems is now on permanent display at the RCA west coast plant in Burbank, California. The equipment, all in full operation, includes Professional Television, Select-a-Lesson information retrieval system, learning laboratory, 2500 MHz transmission system, and audio-visual equipment.

The equipment is housed in Burbank's recently-completed Technical Information Center. Patterned after the RCA Television Training Center in Camden,* the facility is used for demonstrations, training, special meetings, and seminars. It is open to broadcasters, educators, consultants, training directors and others requiring information on Professional Television equipment or complete education systems.

The center was built to provide users with a facility where they can learn about all the latest electronic equipment for education in one location. The nation's educational system is burdened today with a growing student population, rising costs, and increasingly complex subject matter. In an effort to avoid lowering standards, educators now look to the electronics industry for new teaching aids and techniques.

* See BROADCAST NEWS, Vol. 137, January 1968, page 40.

As a result educational technology has been expanding at a rapid pace during the past few years. Educators find it difficult, and understandably so, to evaluate the merits of all the new systems unless they can see them together in one place. RCA offers the most complete line of education systems available, and is uniquely qualified to recommend the type of equipment that will best meet specific requirements.

The center includes four areas: a small television studio, an open area for display of systems, a counter and modular wall for display of small equipment, and a conference and presentation area.

Television Studio

The studio contains complete facilities for camera demonstration and testing, including RCA Professional Television cameras, a fully-equipped control console, an equipment rack, and the latest ColorTran quartz lighting system. Special features of the system are a unique dual-dimmer arrangement and two-color cyclorama lighting. All fixtures are mounted on a ColorTran Grid-King overhead rail system so that fixtures may be moved individually and in groups without removing them from the grid.

Camera demonstrations are conducted with both live models and an "animation unit". This unit contains a variety of items typically used in instructional television, such as a life-size model of the human heart, a slide rule, and pages from an encyclopedia.

Systems Display

The systems display area accommodates large equipment including Select-a-Lesson information retrieval system, learning laboratory, student carrels, Tele-Roamer classroom TV console, and instructor-controlled TV system. Also on display are the RCA 1600 projector and a line of film recording equipment which is manufactured in Burbank for the motion picture industry.

An exciting new instructional system, Select-a-Lesson permits students and faculty to gain access to any of dozens (hundreds) of pre-recorded lessons in audio or video at any time of day. In addition, they can obtain live television or radio programs. Simply dial a number—the lesson begins without delay. Calls can be made from a variety of locations—the classroom, the library, even a distant dormitory. No matter what the location, the quality of sound and picture received is excellent.

The EDC-101 Learning Laboratory is a system in which each student receives a recorded audio lesson selected by the teacher. Further, all students in the classroom can recite simultaneously without disturbing each other. Console controls enable the teacher to monitor and record the student recitations, also talk to students individually or in groups.

Student carrels are booths equipped with a headset and other equipment at which students receive Select-

FIG. 2 Small TV studio contains complete facilities for camera demonstration and testing. Shown left to right are: PTC-2 console with PTS-1 switching system and special effects, camera controls, audio system, and monitors; PK-315 viewfinder camera; "animation unit" used in demonstrations; and PK-330 studio camera.





FIG. 3 Systems area contains (l. to r.) operating Select-a-Lesson information retrieval equipment rack, student carrels, optical recording system, and learning laboratory. Not shown are a TeleRoamer mobile TV console and an instructor-controlled television system for classroom use.

a-Lesson and learning laboratory programs. Styled to complement virtually any room, the carrels may be placed in classrooms, libraries, dormitories, and other locations around a campus.

TeleRoamer is a compact and self-contained television production center on wheels. Teachers can simply roll it into a classroom or studio, plug it in, and start the lesson. At the touch of a button, the teacher can select pictures from camera closeups, films, slides, TV tape, or off-the-air signals. Technical assistance is rarely required, since most teachers can quickly learn how to operate the equipment by themselves.

Instructor-controlled TV systems are simplified versions of TeleRoamer. Basic systems consist of a camera, elevator column, and platform, and permit the teacher to show full-screen enlargements of live science experiments, pictures, transparencies, microscope slides, or virtually any other standard teaching material. With systems like this in schools, gone are the days when students in the back of the room can't see materials the teacher is showing.

Small Equipment Area

Here is a counter and modular wall for display of small equipment. Products such as helical scan recorders, record players, and tape recorders are positioned on the counter for experimentation and inspection. There is also a storage area and files containing catalog sheets and product literature. These are freely available to those who are responsible for planning electronic systems.

The wall behind the counter accommodates miniaturized products such as TV switching modules and remote control panels as well as selected pictures and a display of custom magnetic heads manufactured in Burbank. An ingenious bracket-and-slot design permits items to be removed from the wall quickly for examination and evaluation.

Conference and Presentation Area

Adjoining the small equipment display is a conference area containing a unique and a complete range of built-in presentation facilities. For intimate and compact conference groups a table seats up to 10 people, but it may be folded up and concealed when a larger group must be accommodated. The center comfortably seats up to 30 people.

Presentation facilities are centered on three sliding panels located on the wall at the head of the conference table. The panels may be arranged in a variety of positions so that one, two, or all three are visible. Visual aids which can be used with the panels include flip charts, pictures, posters, films, slides, overhead projection, chalk, and modular system diagrams mounted on magnetic backing. The front panel depicts RCA's activities in broadcasting, education, training and motion pictures.



FIG. 4 Conference and presentation area is centered around sliding panels which accommodate a wide variety of visual aids. Output of any television equipment in the center may be displayed on the ceiling-mounted monitor. Modular wall accommodates television remote control panels, switching and terminal modules, and other small equipment. A helical scan recorder, classroom record player, and tape recorder are located on the counter.

Design of the Center

Before construction was started on the center, several months were required for planning and design. Early in this phase, the following objectives were established:

- The center should be capable of showing, in full operation, the complete range of RCA equipment for education.
- A variety of functional requirements must be met, but they should not degrade the appearance of the room.
- Special equipment not usually on display may be needed for certain meetings. It must be possible to move in and connect such equipment quickly and easily.
- The room should incorporate a high degree of versatility so that new products can be accommodated without major changes to the structure.
- All facilities should be simple to operate so that a wide variety of personnel can use the center with only minimum training.

These objectives were then translated into a comprehensive plan by professional designers. Special features in the center include:

- Power outlets, placed every $2\frac{1}{2}$ feet around the

room, and video cables are completely concealed, yet readily accessible. All television equipment in the systems and small equipment display areas and the studio is connected to the console. Any camera, TV tape recorder, film chain, etc., may be selected on the console switcher for display on the ceiling-mounted monitors in the front of the room.

- Pictures, product identification signs, and light fixtures may be changed or moved around the room in minutes and without tools, facilitating special equipment displays.
- The display stand for the RCA 1600 projector also contains a concealed slide projector. Remote controls for this unit are provided at the presentation panels in the front of the room.

The Technical Information Center was designed and built by Presentation Industries, Inc., of San Gabriel, California.

An appointment to visit the Technical Information Center can be arranged through any RCA broadcast representative. Groups planning educational electronic or TV systems are encouraged to employ the facilities at the Center to assist in their planning. These facilities are available gratis but should be scheduled well in advance to assure having the date required.

**How do you buy
districtwide
telecasting
perfect for black
and white today
...and perfect for
color tomorrow?**

**Buy our black-
and-white 2500
MHz system.
It has color
built in.**

Today, your own instructional TV programs can go into every classroom in your district, in black and white.

Tomorrow, you add color cameras and receivers—but you *don't* make another big investment in a transmitter. Your original RCA transmitter will do the colorcasting to perfection.

And because we supply everything from studio cameras to receivers in the classrooms—plus one-stop service for everything in the system—we can give you the most realistic estimates of equipment requirements and total costs.

When you're committing a lot of school money, shouldn't you protect your original investment by starting with RCA?

For the facts, write RCA Instructional Electronic Systems, Bldg. 15-5, Camden, New Jersey 08102.

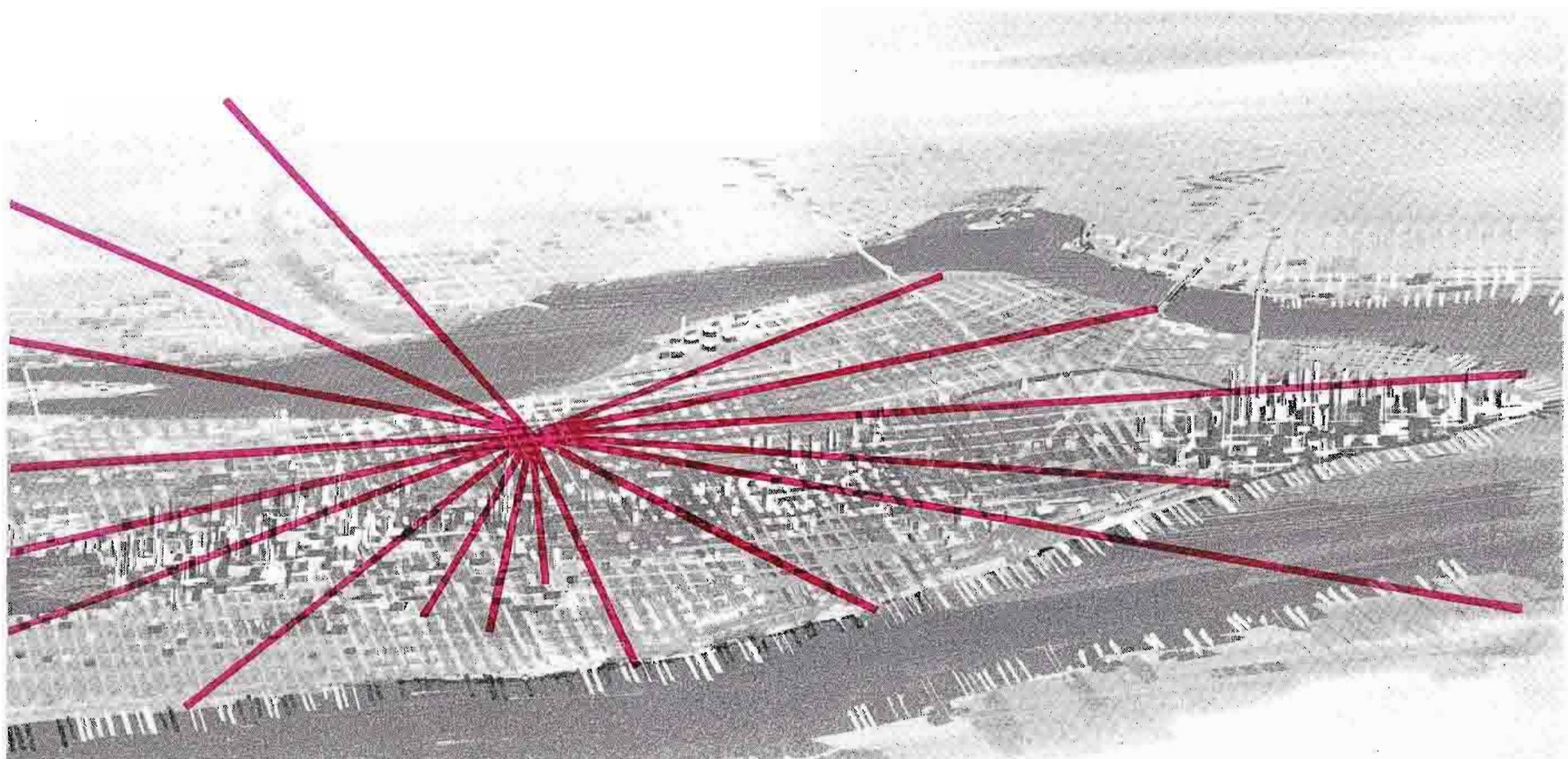

**Does
starting small in
closed-circuit TV
hamper you
when you need
to expand?**

**Not if you
start with
RCA—our
small systems
are designed
to grow.**

But, more to the point, to grow without obsoleting your original equipment. This is important to you since statistics show a marked tendency for expansion after the initial purchase.

And when the day comes for conversion to color TV, you're already well on the way. Our TV control consoles and signal distribution systems are predesigned for high-performance color. Know of anybody else who's working that far ahead to help you protect your original investment?

For the facts, write RCA Instructional Electronic Systems, Bldg. 15-5, Camden, New Jersey 08102.





Now New York's buses talk their way out of trouble.

Today, more than 2,500 New York City Transit Authority buses are RCA 2-way radio-equipped. By the end of this year, 1,700 more buses will go on the air to provide a radio voice for all 4,200 buses in the fleet. In addition, the system includes 250 hand-held 2-way radios to provide a communications link between drivers and supervisors at curbside.

This extensive communications system—the world's largest commercial 2-way radio network—is being used to control and reroute buses away from traffic jams; serves as an effective crime deterrent; provides information and summons assistance, if necessary, for passengers.

The radio system was designed by RCA, working in close conjunction with the Transit Authority. And while the system is tailored to the bus system's specific needs, the heart of the operation is RCA's standard Super-Fleetfone radio. This 100% solid state (no tubes to fail) unit provides such important performance features as continuous duty transmission, instant-on operation and extremely low battery drain. In fact, battery drain is so low that the radio can always be left on, ready for instantaneous communication.

Find out how RCA radio systems can give you better operating efficiency, and improved passenger service. Send coupon for all the facts.

RCA Mobile Communications, Dept. N-497
Bldg. 15-5, Camden, N.J. 08102

- Please send literature.
 Have a Communications specialist call.

Name _____ Title _____

Organization _____

Address _____ Phone _____

City _____ State _____ Zip _____

Here's one way to build a better 2-way radio. Throw out 30 parts.

And put in an integrated circuit instead.

That also eliminates 120 soldered connections. And since reliability is inversely proportional to the number of parts and connections, you've got to end up with a better set.

To give you some idea of just how much better it is, we're even throwing out a few transistors. Nobody else is that far ahead.

We call our new super radio the Super-Carfone 500. It's the only standard commercial 2-way radio with integrated circuitry, and it's the only one with the speaker built into the control head. Compact. Smart looking. And one less unit to clutter

the cab. (But you can still get separate units if you'd rather.)

You can get the Super-Carfone 500 in all frequency bands, too. With up to four-frequency operation and lots of other options. And we think it'll stay on the job longer, and work harder with less downtime than anything else you can buy.

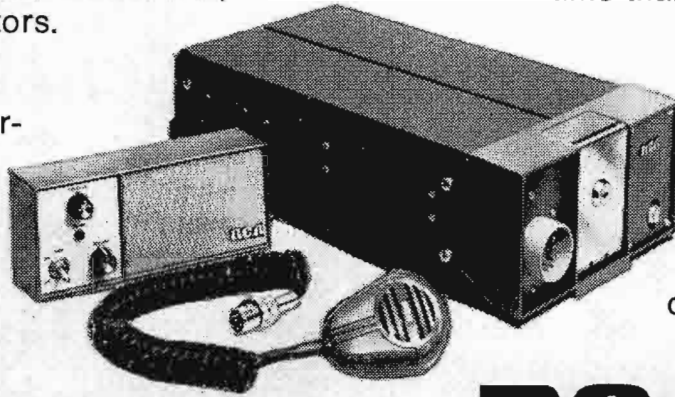

Get your RCA Communications Specialist to bring one over for a quick demonstration. It'll take only a few minutes, and you'll be a little richer for the experience. Or send the coupon for a brochure on the Super-Carfone 500.

RCA Mobile Communications

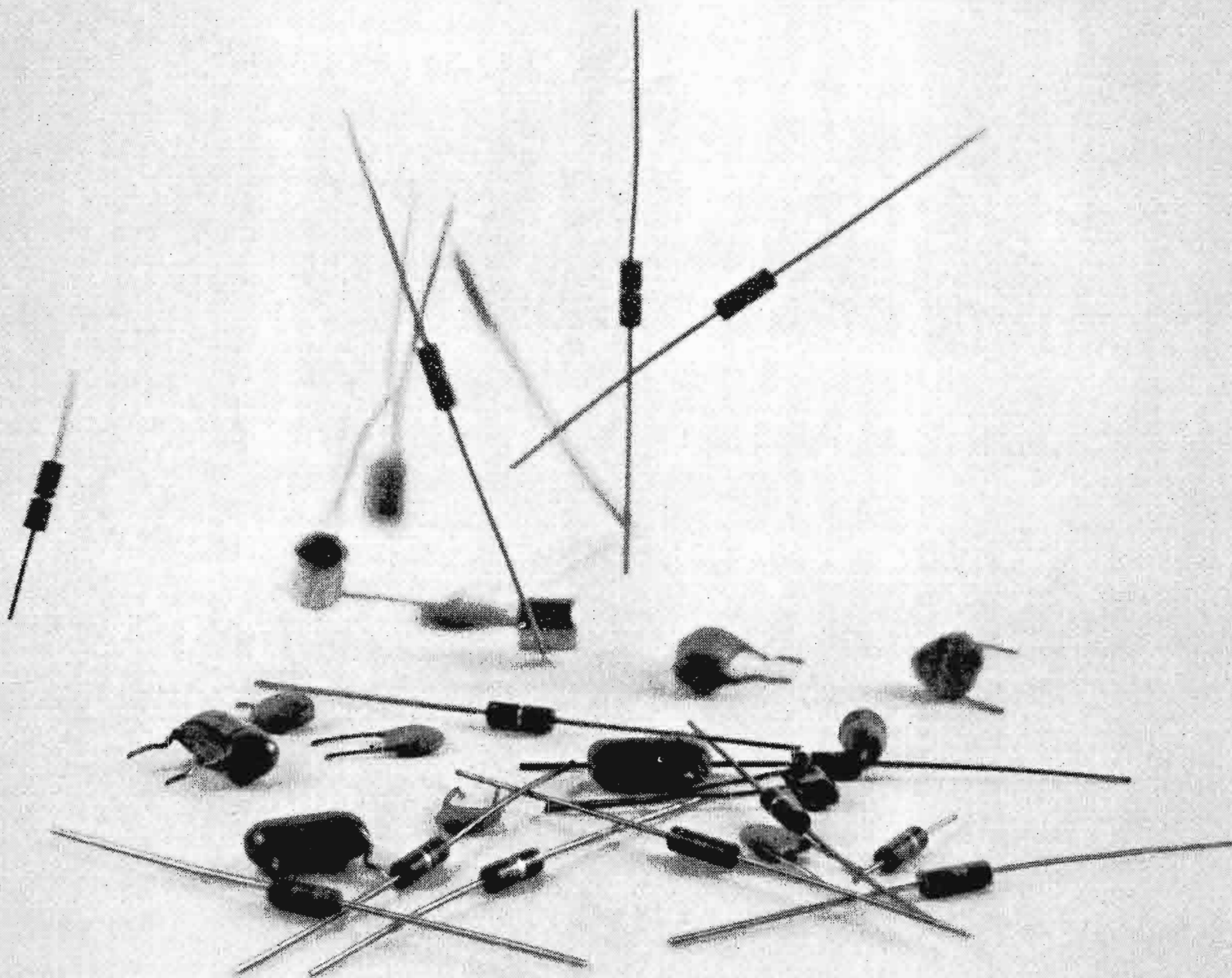

RCA Mobile Communications, Dept. BN, Bldg. 15-5, Camden, N. J. 08102

Send literature on Super-Carfone 500 Have RCA Communications Specialist contact me

Name _____ Title _____

Organization _____

Address _____ Telephone _____

City _____ State _____ Zip _____



Later, he'll make a second-rate tape.

But it's not his fault. Things have just got to go wrong when the controls for any given function are spread all over the recorder. Delays and retaping. Or make-goods. Or worse.

But a tape recorder doesn't have to be designed for the convenience of the manufacturer—from the inside out. At RCA it's got to be designed strictly for the convenience of the user—from the outside in—for absolute simplicity of operation and mainte-

nance. A simple truth . . . but we seem to be the only ones doing it that way.

Consider our TR-70 hi-band, hi-fi color tape recorder. It's intelligently laid out, throughout. Human engineered. Controls are grouped by function. Monitors are eye-level and ear-level. Everything is instantly accessible, convenient, efficient.

Operation is so straightforward we defy anyone to make a bad tape on it. Even its fourth-generation tapes are excellent by any standards.

In fact, with accessories, the TR-70 is really a com-

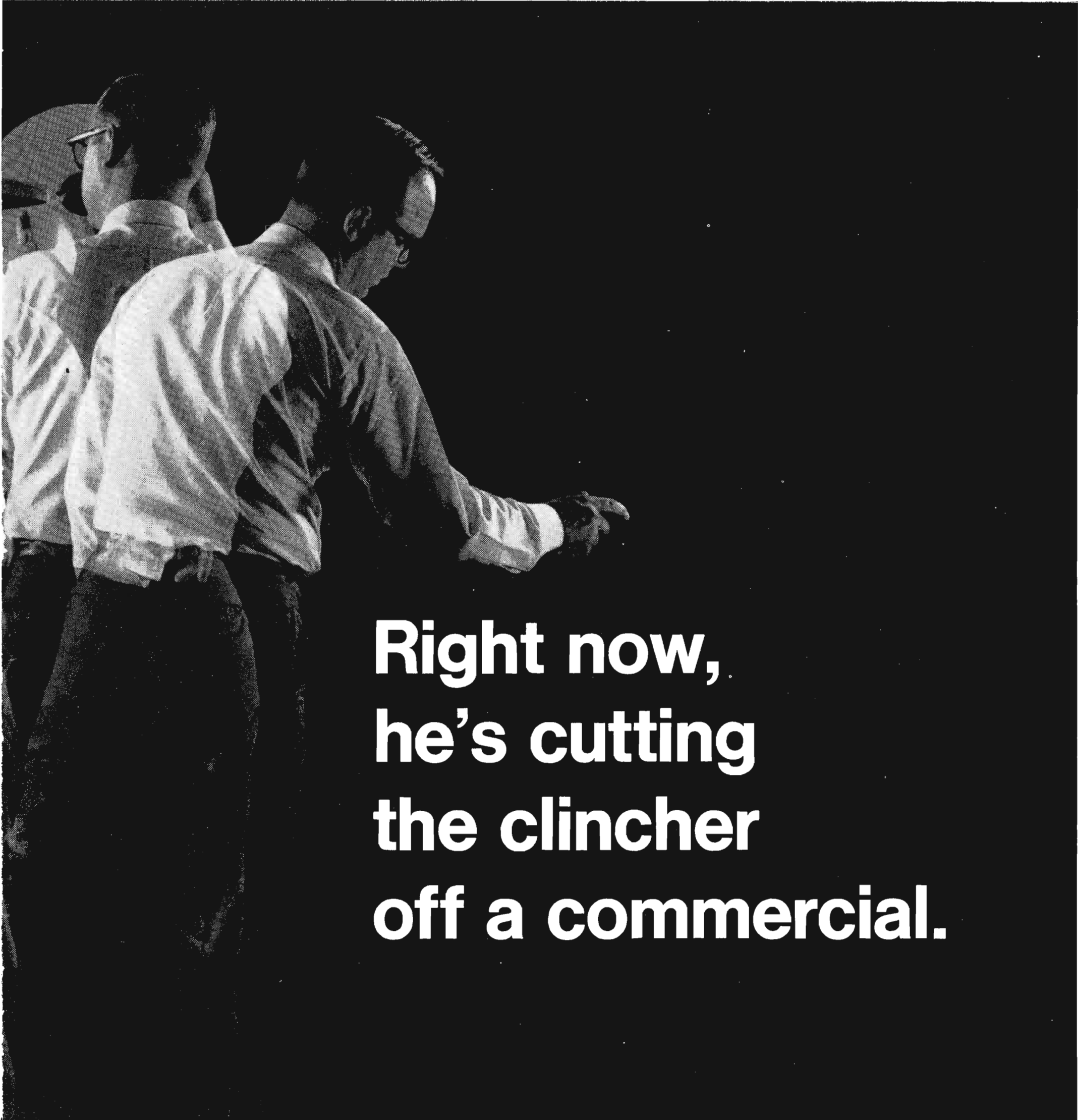

**Right now,
he's cutting
the clincher
off a commercial.**

plete color teleproduction system. It automatically corrects those substandard outside tapes line-by-line, including drop-outs. It has push-button editing, automatic splicing, too.

If you're interested in numbers, it has the world's best specs in K factor, moire, differential phase, differential gain. And its performance is superb under the critical 20T pulse test.

But what we're really talking about here is the clearly visible, unquestionable superiority of tapes made on the TR-70.

If you don't believe the difference can be that obvious, you and your chief engineer owe yourselves a look at the TR-70.

To arrange it, call your RCA Field Man. Or write RCA Broadcast and Television Equipment, Bldg. 15-5, Camden, N. J. 08102.

RCA Broadcast
Equipment

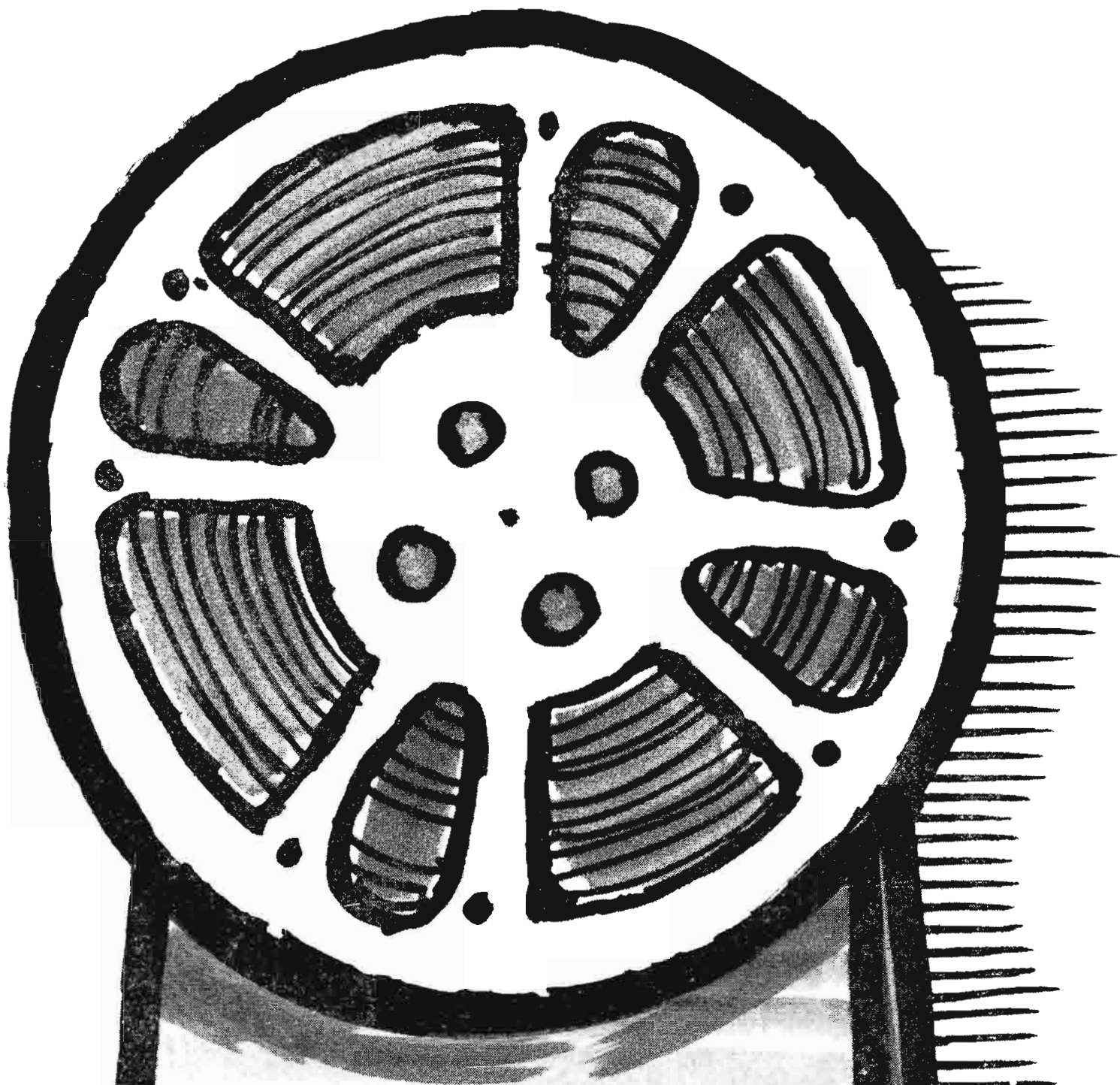

SERVICE

Cancel out TV film projector blues! Preventive service—a planned protection program of RCA Service Company—means regularly scheduled or hurry-up remedial attention. Dependable replacement parts, too, of course. All handled expertly by trained RCA specialists. There's no better formula for keeping your film projector—and other electronic gear—working well! It took a company which understands broadcasters' needs for top performance levels, efficiency and economy in operation of equipment to devise this program of expert service on a contract basis. So, no more blue days...check out your service needs with us.

RCA Service Company
A Division of RCA
Technical Products Service
Bldg. CHIC-225, Camden, N. J. 08101
Phone: (609) 963-8000, ext. PH-311



Color Films Come Alive

... in their Original Brilliance
with the RCA "Big Tube"
Color Film System



The "Big Tube" concept in color film cameras assures reproduction of programs and commercials in all their original beauty. Film and slide subjects have the natural look of colors that are faithfully reproduced. Pictures are brilliant, films have snap and sparkle—to entertain, to educate, and to sell.

By using a Big Tube—50% larger than others use—RCA gives you greater resolution. It's like using a big negative in photography. The picture is sharper, the focus is uniform—all over the screen. Outdoor and indoor subjects, close-ups and macro-shots, all reflect the higher resolving power.

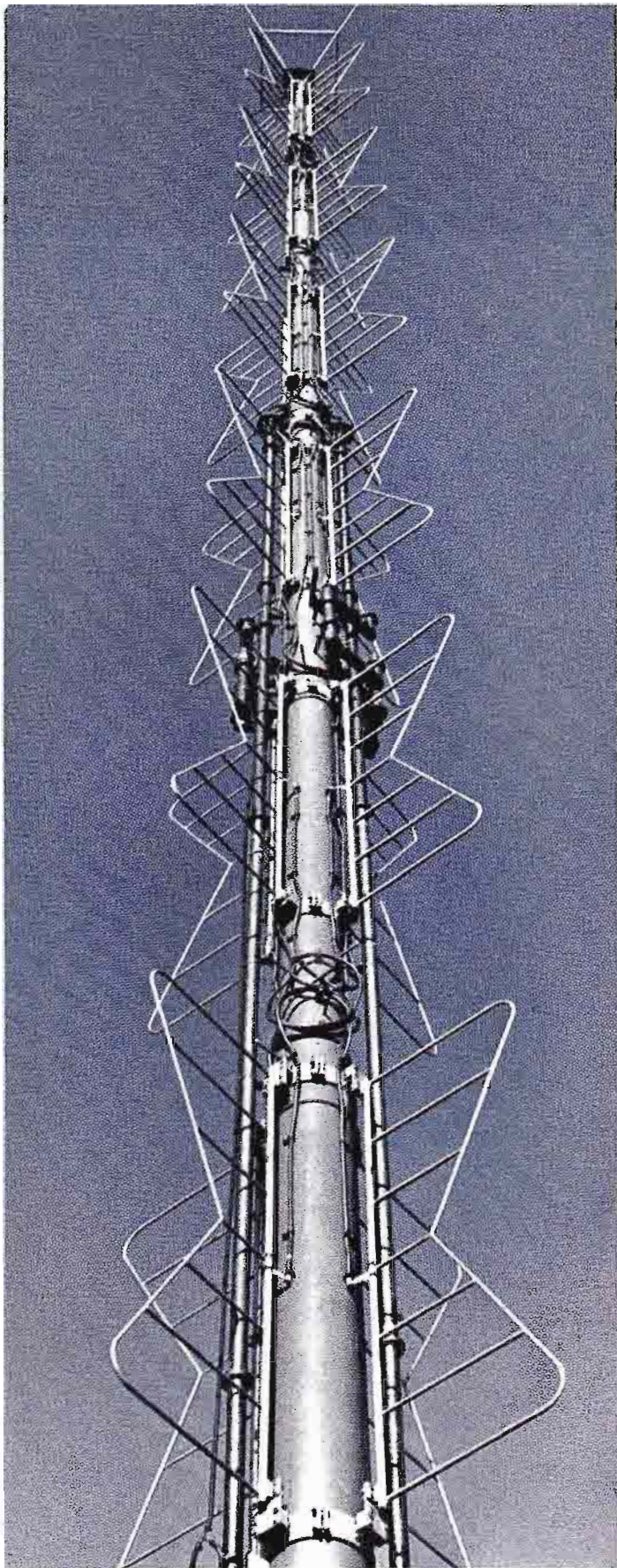

RCA Gibbsboro Where Most of the TV Antennas Come From...

A World of Broadcast Antenna
Engineering Capability



RCA Super Turnstile VHF Antenna has long been the standard of the TV industry.

UHF Panel Antenna one of the newest members of evergrowing RCA family of antennas.

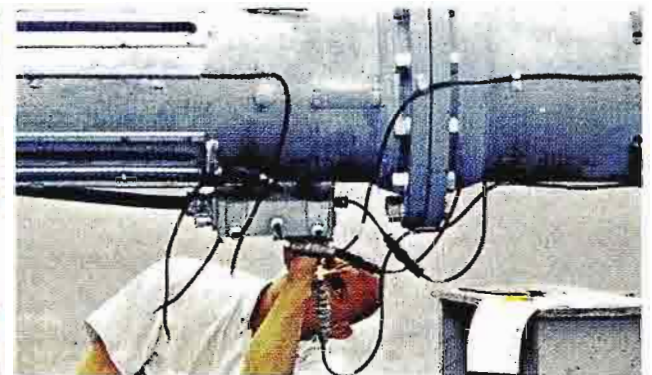

Connecting de-icer on an RCA Pylon—long time favorite of UHF broadcasters.

For more information call your RCA Broadcast Representative. Or write RCA Broadcast Systems, Bldg. 15-5, Camden, N.J. 08102.

RCA Broadcast
Equipment